

# PELab USER GUIDE

Revision 1.1

## SAFETY NOTICE

This Device is ESD Sensitive and Needs to be Handled with Care. High Voltage Condition May Occur During Operation of the Device, and Hence User is Solely Responsible for Equipment and Personnel Safety. Taraz Technologies Shall Not be Hold Liable for any Damage to Personnel and/or Properties as a Result of Using this Device. User Must Take Adequate Steps to Ensure Electrical and Mechanical Safety of the Device in Use.

## WARNING & DISCLAIMER

The Information Herein is Given to Describe Certain Components and Shall Not be Considered as a Guarantee of Characteristics. Terms of Delivery and Rights to Technical Change Reserved. We Hereby Disclaim any and All Warranties, Including But Not Limited to Warranties of Non-Infringement, Regarding Circuits, Descriptions, and Charts Stated Herein. Customer is Solely Responsible for Proper and Legal Use of all Products Offered by Taraz Technologies.

Data subject to change. Copyright © 2021 Taraz Technologies. All rights reserved.

## CONTACT

### TARAZ TECHNOLOGIES

21-X, 2nd Floor, DHA Business Avenue, DHA Phase 1,  
Bahria Expressway, Rawalpindi 46000, Pakistan.

**Phone: +92 (51) 5400335**

**Fax: +92 (51) 5400155**

**E-Mail: [sales@taraztechnologies.com](mailto:sales@taraztechnologies.com)**

**Website: [www.taraztechnologies.com](http://www.taraztechnologies.com)**



# TABLE OF CONTENTS

- Table of Contents ..... 2**
- Safety Information ..... 3**
- Revision History ..... 5**
- Getting started ..... 6**
  - Unpacking ..... 6
  - Package Contents ..... 6
  - Mounting ..... 7
  - System Architecture..... 8
  - Front Panel ..... 9
  - Rear Panel ..... 10
  - Power and Earth ..... 10
  - System Connections ..... 11
- Operation Information ..... 12**
  - Overview ..... 12
  - Operation Modes ..... 13
  - Pin Mapping & Connections ..... 20
  - Protections ..... 22
  - Circuit Configuration ..... 23
  - Operation Procedures & Precautions ..... 24
  - PEController Overview ..... 25
- Ordering Guide..... 28**
  - Ordering Options ..... 28
  - Options Summary & Pricing Information ..... 30
- Specifications ..... 31**
  - General Specifications..... 31
  - Measurements ..... 31
  - Derating Curves ..... 32
  - Mechanical ..... 33
  - PELab-6PH Specifications ..... 34
  - PELab-MMC Specifications ..... 34
  - PELab-TNPC Specifications..... 34
  - PELab-NPC Specifications ..... 34
- Annex A ..... 36**
  - PELab-6PH Datasheet Sample..... 36

## SAFETY INFORMATION

The following safety precautions apply during all phases of operation, service, and repair of this equipment.

- Read and understand the safety and operational information in this manual.
- Apply all the listed and industry recommended safety precautions.
- Make all connections before applying power.
- Do not operate the equipment in ways not specified by this manual.

Failure to comply with these precautions and warnings in this manual violates the safety standards of design, manufacture, and intended use of this equipment, and Taraz Technologies shall not be held liable for any failure resulting from non-compliance.

### Ground (Earth) the Equipment

To minimize shock hazards, the equipment chassis and cabinet must be connected to the electrical safety ground. This equipment is grounded through the ground conductor of the supplied, three-conductor AC line power cable and/or other specified connectors in this manual. The power cable must be plugged into an approved three-conductor electrical outlet. The power jack and mating plug of the power cable must meet IEC safety standards. Do not alter or defeat the ground connection. Without the safety ground connection, all accessible conductive parts including the control knobs and buttons may provide an electric shock. Failure to use a properly grounded approved outlet and the recommended three-conductor AC line power cable may result in injury or death.

### Do Not Operate in an Explosive or Flammable Atmosphere

Do not operate the equipment in the presence of flammable gases or vapors, fumes, or finely divided particulates. The equipment is designed to be used in laboratory/office indoor environments. Do not operate the equipment:

- In the presence of noxious, corrosive, or flammable fumes, gases, vapors, chemicals, or finely-divided particulates.
- In relative humidity conditions outside the equipment's specifications.
- In environments where there is a danger of any liquid being spilled on the equipment or where any liquid can condense on the equipment.
- In air temperatures exceeding the specified operating temperatures.
- In atmospheric pressures outside the specified altitude limits or where the surrounding gas is not air.
- In environments with restricted cooling airflow, even if the air temperatures are within specifications.
- In direct sunlight.

This equipment is intended to be used in indoor pollution degree 2 environments. The operating temperature range is 0 °C to 40 °C and the operating humidity is 90% relative humidity with no condensation allowed.

Measurements made by this equipment may be outside specifications if the equipment is used in non-laboratory/office-type environments. Such environments may include rapid temperature or humidity changes, sunlight, vibration and/or mechanical shocks, acoustic noise, electrical noise, strong electric fields, or strong magnetic fields.

### Do Not Operate the Equipment if Damaged

If the equipment is damaged, appears to be damaged, or if any liquid, chemical, or other material gets on or inside the equipment, remove the equipment's power cord, remove the equipment from service, label it as not to be operated, and return the equipment to Taraz Technologies for repair. Inform Taraz Technologies of the nature of the contamination.

### Clean the Equipment Only as Instructed and/or Required

Do not clean the equipment, its switches, or its terminals with contact cleaners, abrasives, lubricants, solvents, acids/bases, or other such chemicals. Clean the equipment only with a clean dry lint-free cloth or as instructed in this manual.

### Not for Critical Applications

This equipment is not authorized for use in contact with the human body or for use as a component in a life-support device or system.

## Do Not Touch Internal Circuits

Equipment cover must not be removed by operating personnel. Taraz Technologies must be informed prior to component replacement and/or internal adjustments, and must be made only by qualified maintenance personnel who are aware of the hazards involved when the equipment's covers and shields are removed. Under certain conditions, even with the power cord removed, dangerous voltages may exist when the covers are removed. To avoid injuries, always disconnect the power cord from the equipment, disconnect all other connections (for example, test leads, computer interface cables, etc.), discharge all circuits, and verify there are no hazardous voltages present on any conductors by measurements with a properly-operating voltage-sensing device before touching any internal parts. Verify the voltage-sensing device is working properly before and after making the measurements by testing with known-operating voltage sources and test for both DC and AC voltages. Do not attempt any service or adjustment unless another person capable of rendering first aid and resuscitation is present. Do not insert any object into an equipment's ventilation openings or other openings. Hazardous voltages may be present in unexpected locations in circuitry being tested when a fault condition in the circuit exists.

## Fuse Replacement

Fuse replacement must be done by qualified maintenance personnel who are aware of the equipment's fuse requirements and safe replacement procedures. Disconnect the equipment from the power line before replacing fuses. Replace fuses only with new fuses of the fuse types, voltage ratings, and current ratings specified in this manual or on the back of the equipment. Failure to do so may damage the equipment, lead to a safety hazard, or cause a fire. Failure to use the specified fuses will void the warranty.

## Servicing

Do not substitute parts that are not approved by Taraz Technologies or modify this equipment. Return the equipment to Taraz Technologies for service and repair to ensure that safety and performance features are maintained.

## Cooling Fans

This equipment contains one or more cooling fans. For continued safe operation of the equipment, the air inlet and exhaust openings for these fans must not be blocked nor must accumulate dust or other debris be allowed to reduce airflow. Maintain at least 25 mm clearance around the sides of the equipment that contain air inlet and exhaust ports. If mounted in a rack, position other heat emitting devices in the rack above the equipment to minimize equipment heating while rack mounted. Do not continue to operate the equipment if you cannot verify the fan is operating (note some fans may have intermittent duty cycles). Do not insert any object into the fan's inlet or outlet.

## Use Correctly Sized Wires and Connectors

To connect loads and sources to this equipment, use a wire diameter large enough to handle the maximum continuous output current without the wire overheating.

## For Continued Safe Use of the Equipment

- Do not place heavy objects on the equipment.
- Do not obstruct cooling airflow to the equipment.
- Do not place a hot soldering iron on the equipment.
- Do not pull the equipment with the power cord, connected probe, or connected test lead.
- Do not move the equipment when a probe is connected to a circuit being tested.
- Do not exert pressure on the equipment control knobs, buttons, switches and connectors.

## REVISION HISTORY

Revision	Date	Changes Description
1.0	25-09-2021	Initial release
1.1	07-06-2022	Options summery and pricing information section updated

## GETTING STARTED

### Unpacking

The PELab is shipped in a wooden box to ensure safety during shipping. The box can be opened without tools. Once opened, remove the accessories from the sides first. To unpack the PELab, **pull it from the orange strips and lift vertically**, ensure that **no stress is exerted on the front or rear panel components especially the knob and connectors**.

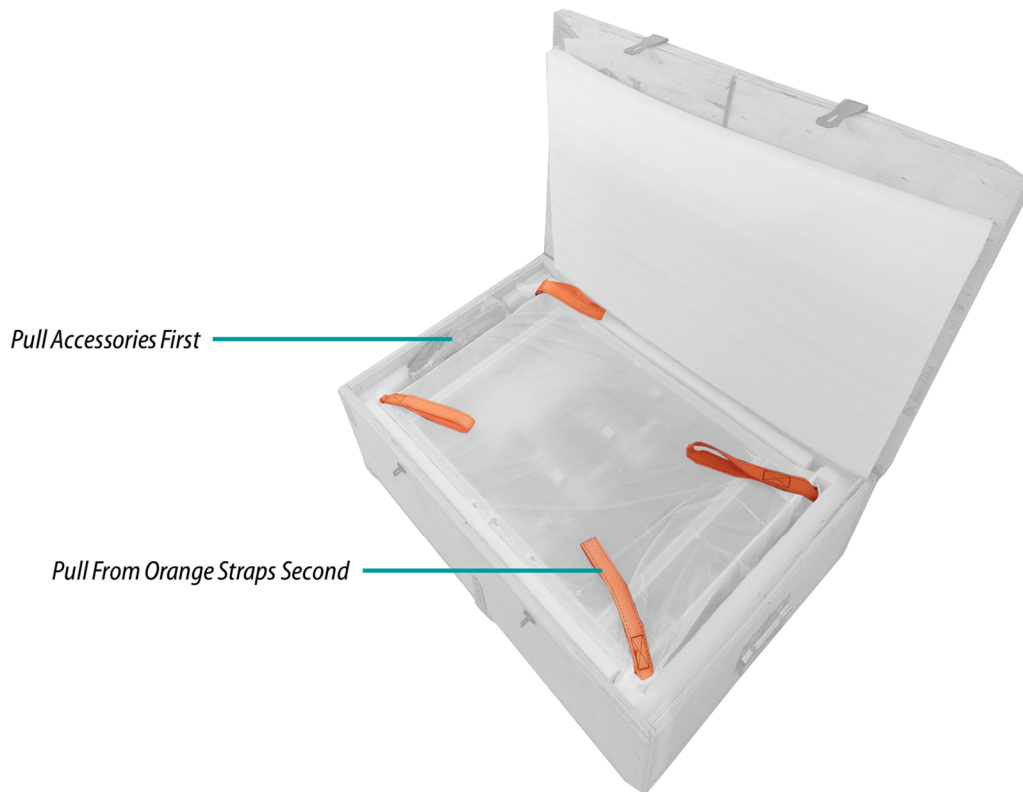

### Package Contents

The package should include the following equipment and components. Inspect the package to make sure nothing is damaged. The PELab includes the following basic hardware:

Item	Description
PELab-XXX	The ordered configuration of PELab
Power Cable	Power cable to power up the PELab logic and gate driver circuitry
USB to USB Cable	USB to USB cable for programming the embedded controller (if PEController is included in configuration)
Banana Jumpers	An easy connection jumpers between power modules and other components, quantity depends on configuration
CT100	CT100 100A Current sensors if the rear panel includes the optional current sensors
Screws	8x screws for rail slide mounting, 4x screws for the front panel mounting

## Mounting

The PELab models are designed for mounting in a standard 19-inch equipment rack compliant to EIA-310. User can mount the PELab unit on a rack tray or the suggested rack mount slides (Accuride 2907WB).

### Assembly Steps for 2907WB Rack Slides (Optional)

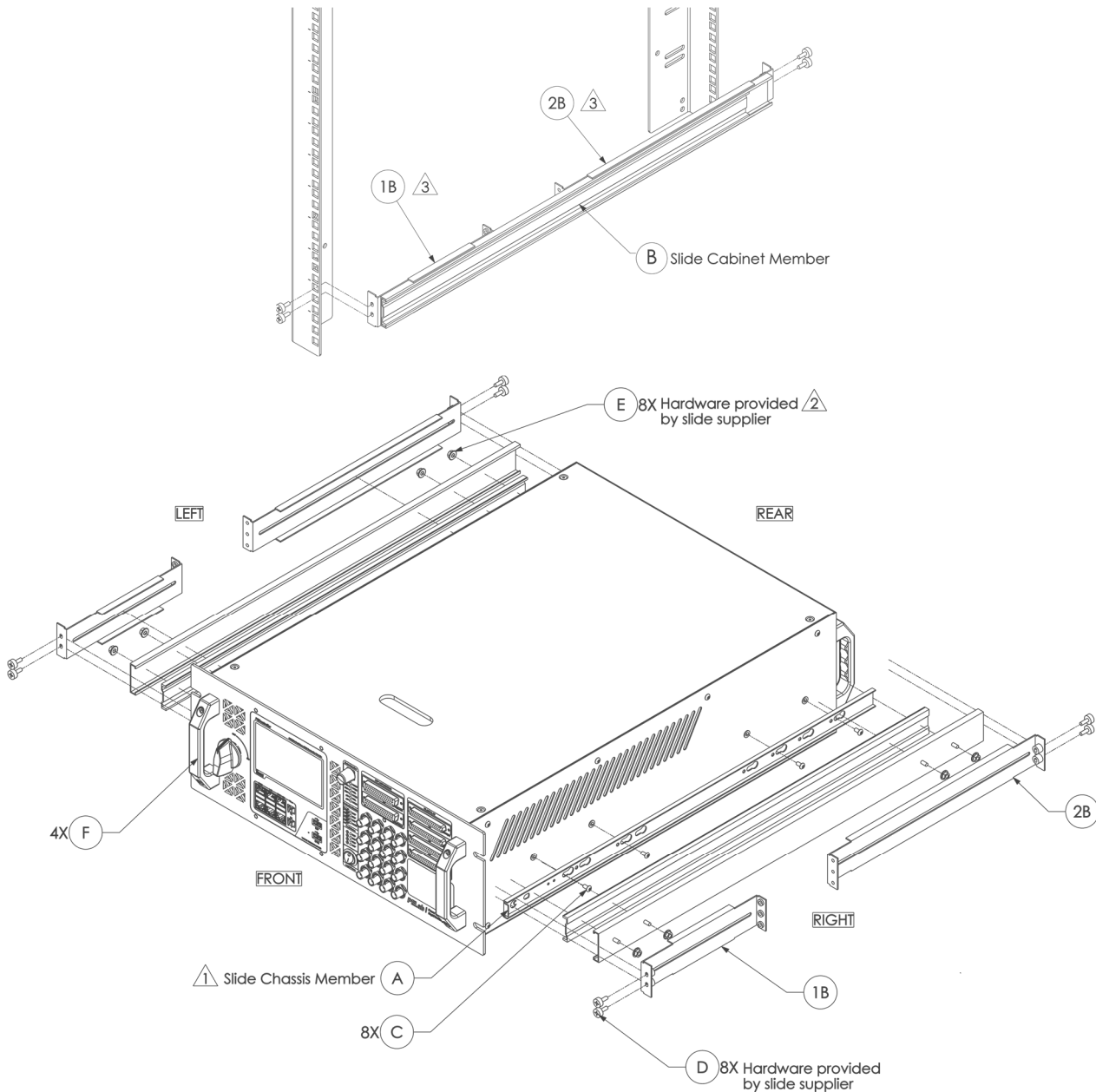

- Note **1** Install slide chassis members **A** on both sides of PELab chassis using **C** screws provided in the accessories pack kit. Ensure that spring latch orientation is correct.
- Install the slide brackets **1B** and **2B**, to the stationary slide sections, with the **E** hardware provided by the slide supplier as shown in Note **2**.
- Note **3**, Adjust the location of the mounting brackets as required for the particular type of cabinet vertical rails. Note that the mounting brackets have two possible positions to allow alignment to EIA hole patterns, the fixed 3-hole spacing as well as the adjustable 2-hole locations to accept both 12.7mm and 15.9mm pitch patterns.
- Insert the thumb screws provided by slide supplier **D** through the cabinet rail and threaded holes of the bracket.
- Extend slide cabinet members to its fully locked position. Carefully Insert the PELab unit with chassis member **A** into the slide cabinet member **B** and close completely. Adjust slide alignment until the movement is smooth, tighten all screws, and complete installation.
- Secure the front panel of the PELab chassis to the cabinet rack rails using the screws provided in the accessories pack kit.
- To remove the PELab chassis, lift the lever on the left-hand slide up and the lever on the right hand slide down.

## System Architecture

The PELab is made of independent products that can be purchased separately as well. This makes the system modular and maintainable. It consists of the following components:

- Power modules with optimized gate drivers (SPM Series)
- Isolated voltage and current sensors (USM-3IV)
- Inductors, EMC filters, and relays
- Embedded ARM microcontroller with 5" touch display (PEController)
- Interface card with multiplexing logic to connect with the real-time simulator and RCP simultaneously

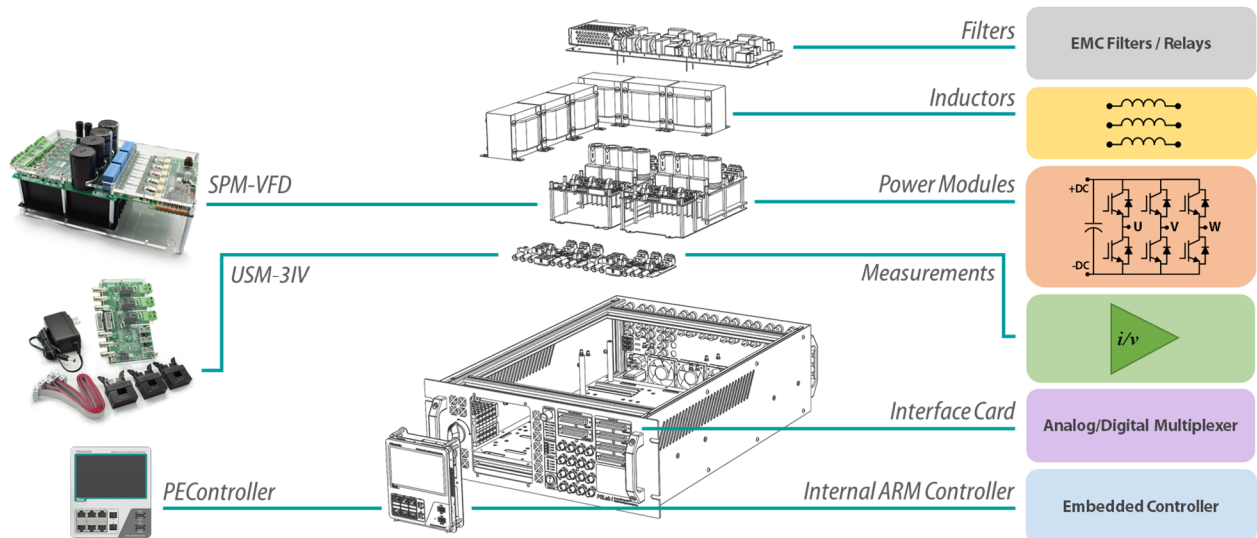



Front Panel

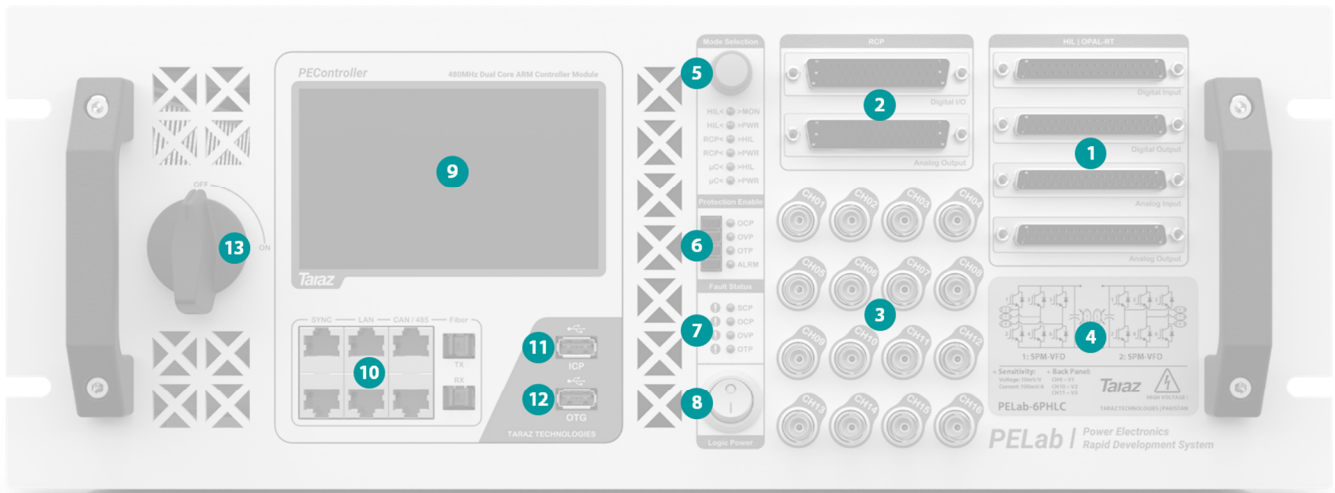

- 1** DB37 connectors to interface with real-time HIL/RCP simulator (direct connection to OPAL-RT)

**2** DB50 connectors to interface with RCP and other controllers (direct connection to dSPACE MLBX)

**3** BNC connectors with isolated measurements to interface with oscilloscopes and RCPs

**4** Measurements label

**5** Mode selection control knob

**6** Fault enable/disable control

**7** Fault status indications
- 8** Logic power supply ON/OFF button

**9** PEController (embedded dual-core ARM M7/M4 based microcontroller with 5" touch display)

**10** Communication connectors including Sync, LAN, CAN, RS485 and Fiber Optics

**11** USB port for ICP (In Circuit Programming and Debugging)

**12** USB port for data

**13** Cutoff switch (connections on the rear panel)

Rear Panel

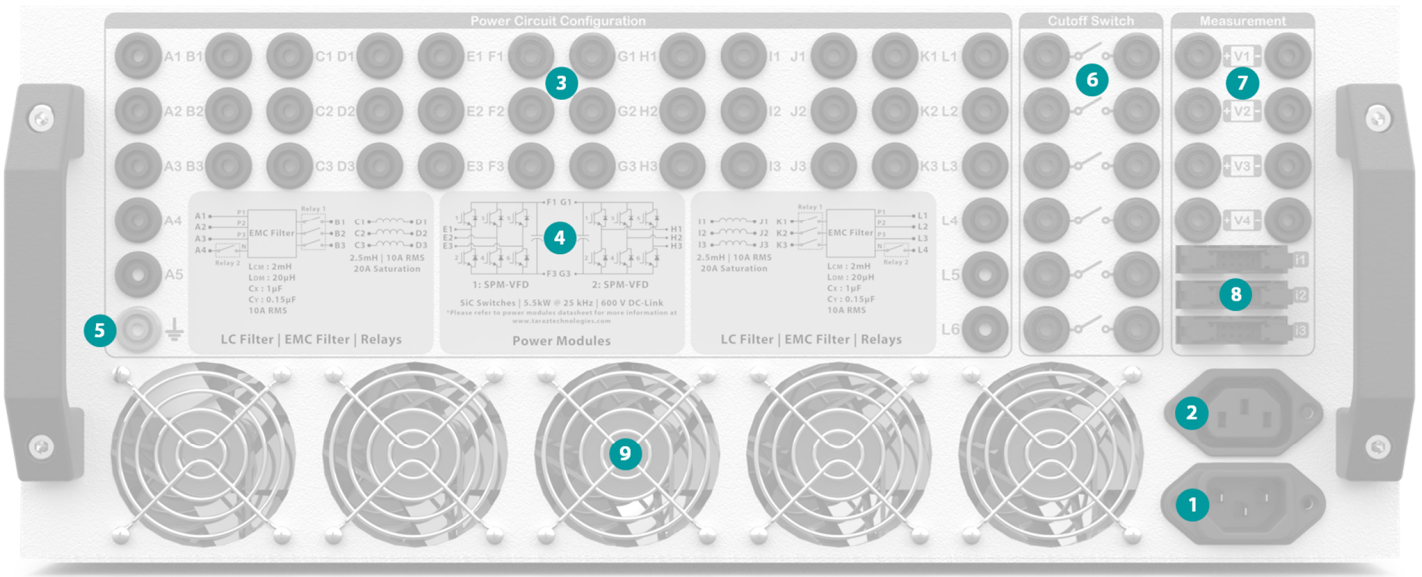

- 1 Logic power supply input (85~264VAC | 120~373 VDC)
- 2 Logic power supply output to next PELab
- 3 Power circuit connections
- 4 Power circuit configuration labels
- 5 Connection for earth
- 6 Cutoff switch poles
- 7 Optional isolated voltage sensors
- 8 Optional current sensor connectors
- 9 Cooling fans

Power and Earth

The PELab requires logic AC power source to drive the logic and gate drive circuitry, a universal input AC/DC converter inside the PELab generates 15V DC with a maximum power rating of 75W. A second connector (2) outputs the same AC source that is given in the first connector (1) so that a series connection of multiple PELabs is possible. **Please ensure the earth is always connected to the earth connector (5) for safety.**

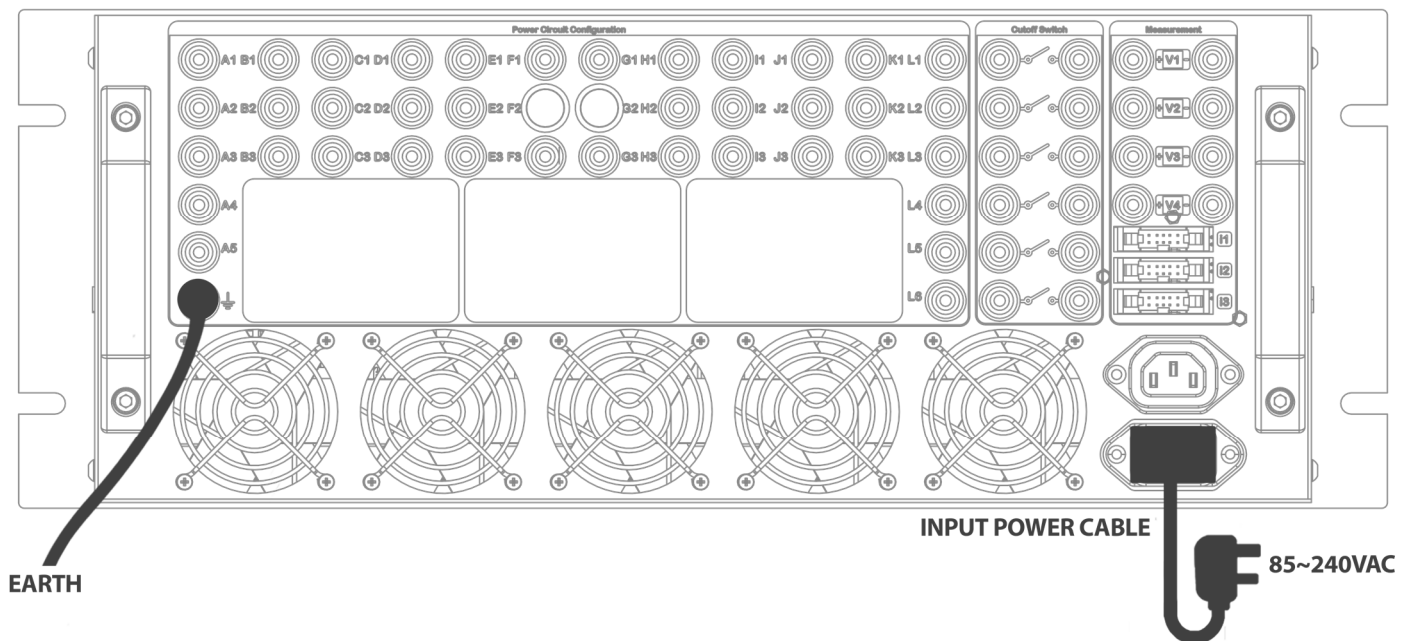

INPUT POWER CABLE 85~240VAC

## System Connections

The PELab can connect to multiple devices simultaneously. To enable all operation modes, a real-time HIL simulator is required along with an RCP. The real-time simulator can have dual functionalities of HIL and RCP, which is supported by OPAL-RT real-time simulators. The PELab uses DB37 connectors for the real-time simulator which are universal to OPAL-RT devices, and a DB50 connectors for the RCP interface, which can be connected directly to dSPACE MLBX RCP.

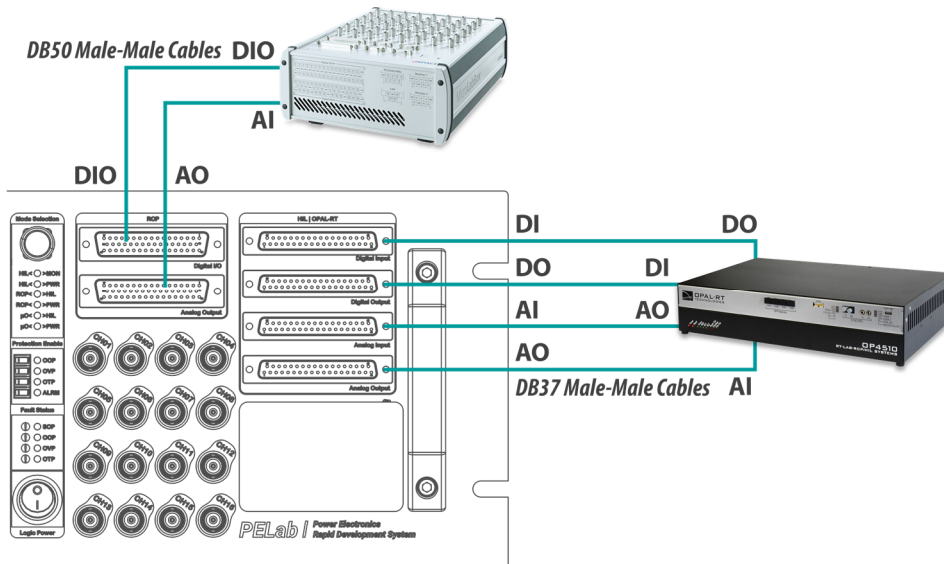

## OPERATION INFORMATION

### Overview

The PELab is a modular power electronics development system that connects to multiple controllers and real-time HIL simulator simultaneously. The PELab can operate in multiple modes that make the research and development cycle faster. It features fully isolated measurements that can connect to oscilloscopes directly without any probes and includes advanced protection features such as SCP, OCP, OVP & OTP. The PELab also includes an industrial-grade embedded controller based on ARM Cortex M7/M4 dual-core microcontroller with an integrated 5" touch display and multiple communication ports. The PELab can be ordered with various commonly used power electronics topologies, while the connectors on the rear panel enable different application circuit configurations.

Generally, a serial process is followed for power electronics research and development. The validation stages start with simulation, followed by rapid control prototyping (RCP). The prototyped control is validated through Hardware-in-the-Loop (HIL) simulation and then with actual hardware. Finally, an embedded controller is developed to be used in the final product, which again goes through HIL validation and hardware validation stages.

Usually, going back and forth between the different validation stages is required for optimization and testing, for example, a certain load or source conditions may not be possible with hardware validation which then can be tested in the HIL validation stage. Typically, a different setup and wiring are required for each stage, which makes changing between the stages difficult. This is solved by the different operation modes of the PELab which enable a rapid development environment where setup is constant while modes are changing by a control knob. The PELab internal multiplexing logic routes the signals between each device to enable the required validation stage.

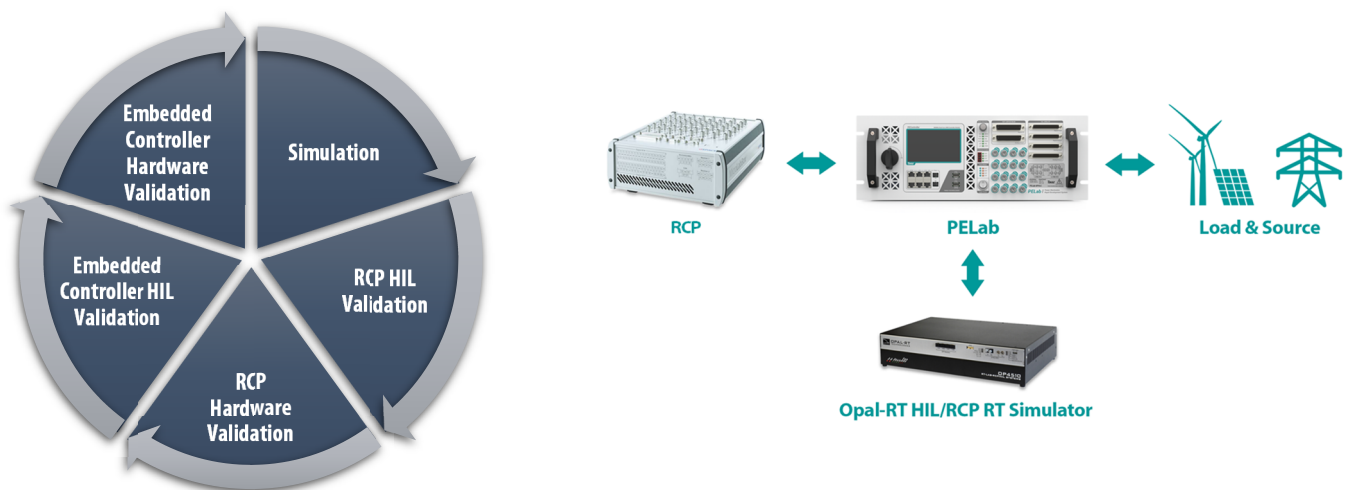

## Operation Modes

The PELab accelerates the power electronics research and development by enabling a single setup for all the validation stages in the R&D cycle. The validation stages are as follows:

1. **Simulation:** simulate the control system & circuit topology in the real-time simulator
2. **RCP HIL validation:** develop control system in RCP & test it with HIL real-time simulator
3. **RCP hardware validation:** test the developed control system in RCP with power electronics hardware
4. **Industrial controller HIL validation:** develop control system in embedded controller & test it with HIL real-time simulator
5. **Industrial controller hardware validation:** test the developed control system in the industrial controller with power electronics hardware

The operation mode can be selected using the knob on the front panel. A multiplexing logic routes the analog and digital signals between three controllers and two targets. The targets are either the actual power electronics hardware inside the PELab or a simulated power electronics inside the real-time simulator. This enables seamless shifting between the different validation stages.

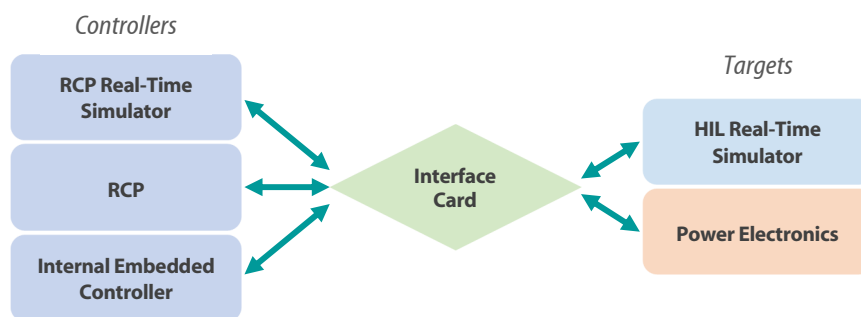

**HIL<>MON MODE: Real-Time Simulation Monitoring**

In HIL Monitoring mode, the real-time simulator will simulate the whole system and send the analog measurements to the PELab. In return, the PELab will send the OCP and OVP signals to the simulator; which are then included in the simulation to make it as close as possible to the hardware implementation. The measurements can be monitored through the BNC connectors using the oscilloscope.

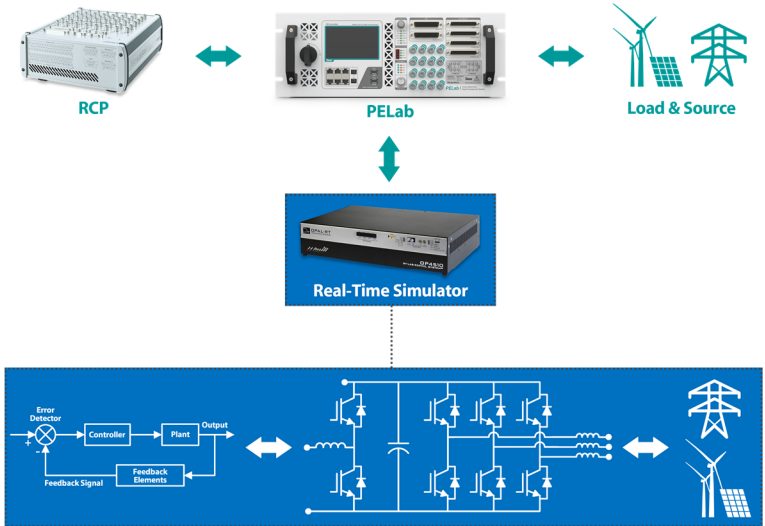
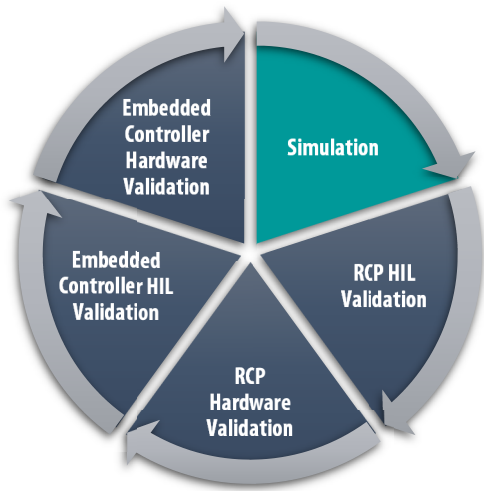

**HIL<>MON Mode Mapping**

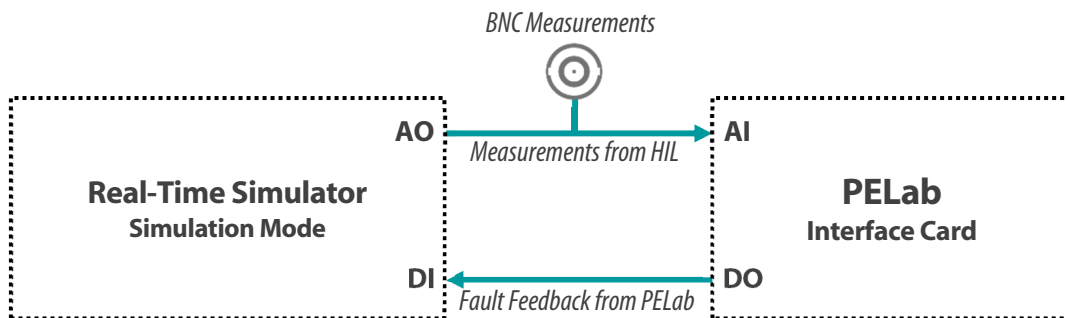

**HIL<>PWR MODE: Real-Time Simulator RCP Hardware Validation**

Next, the real-time simulator is operated as an RCP, the PELab will be in HIL to Power mode, and the PWM signals will be generated by the real-time simulator and will go to the power electronics hardware inside the PELab.

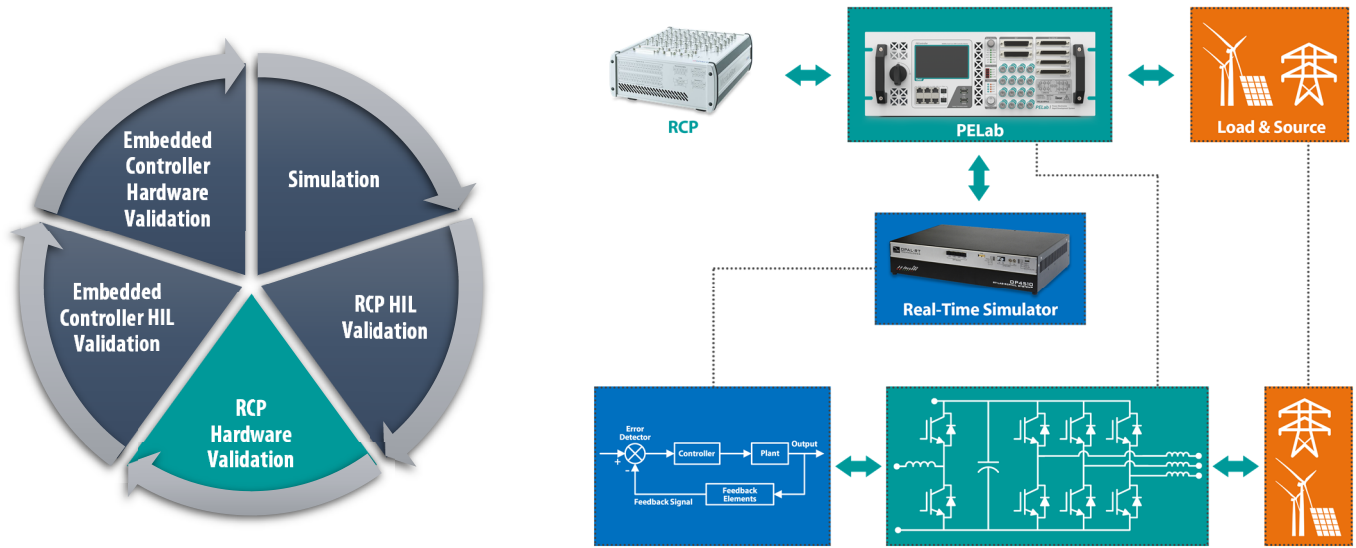

**HIL<>PWR Mode Mapping**

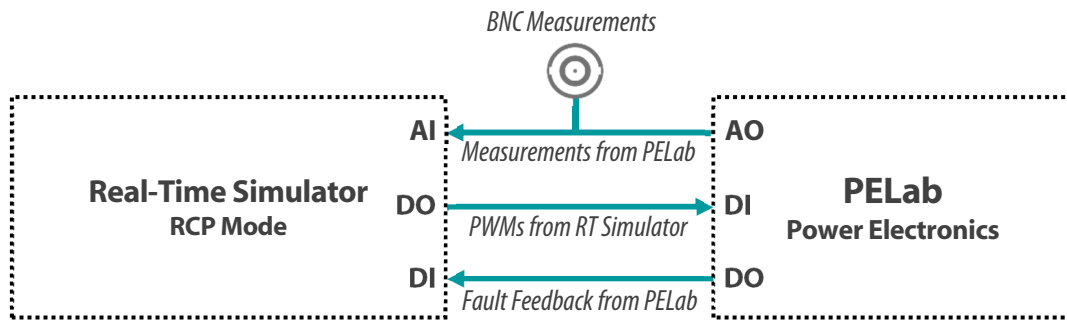

**RCP<>HIL MODE: RCP HIL Validation**

The third mode in the PELab is RCP to HIL, the control signals are generated from the RCP, and tested with a simulated inverter in the real-time simulator.

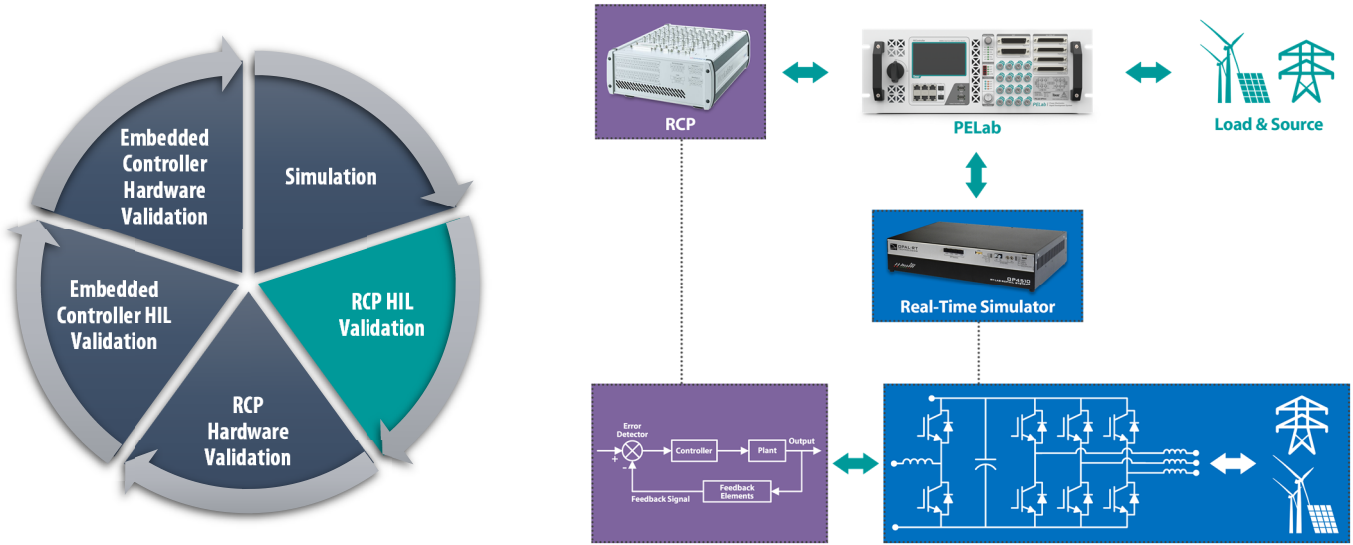

**RCP<>HIL Mode Mapping**

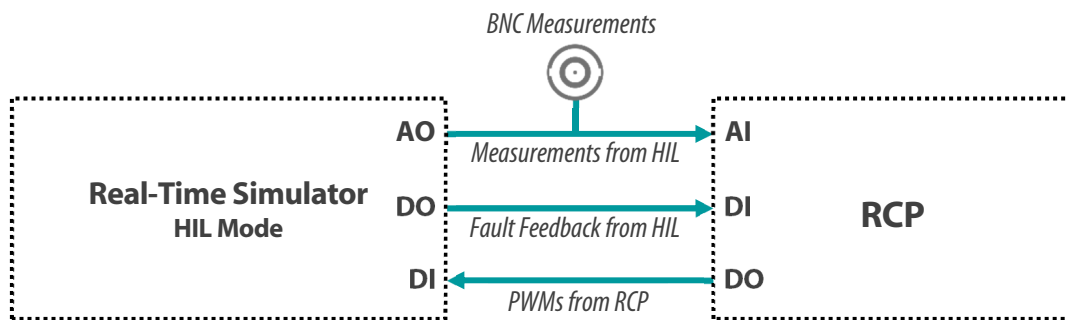



**RCP<>PWR MODE: RCP Hardware Validation**

Once the HIL validation of the RCP is done, the RCP controller can be validated with the actual power electronics hardware in RCP to power mode.

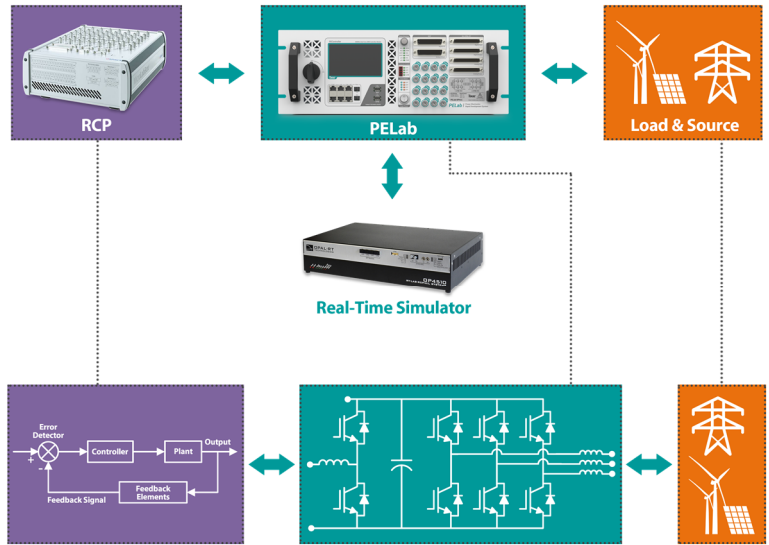
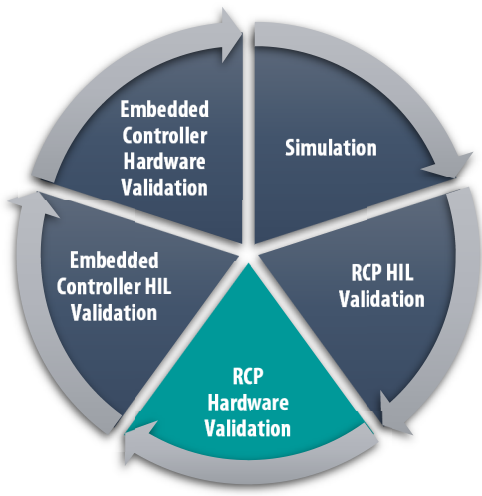

**RCP<>PWR Mode Mapping**

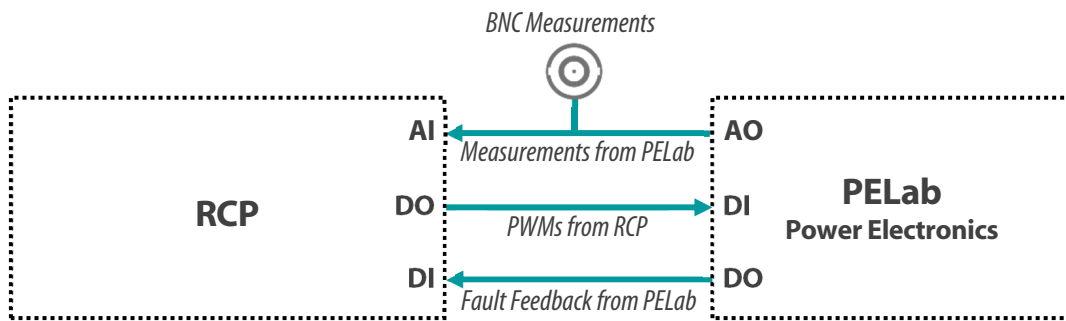

**μC<>HIL MODE: PEController HIL Validation**

In microcontroller to HIL mode, the control system is developed in the PEController and tested with a simulated inverter in the real-time simulator.

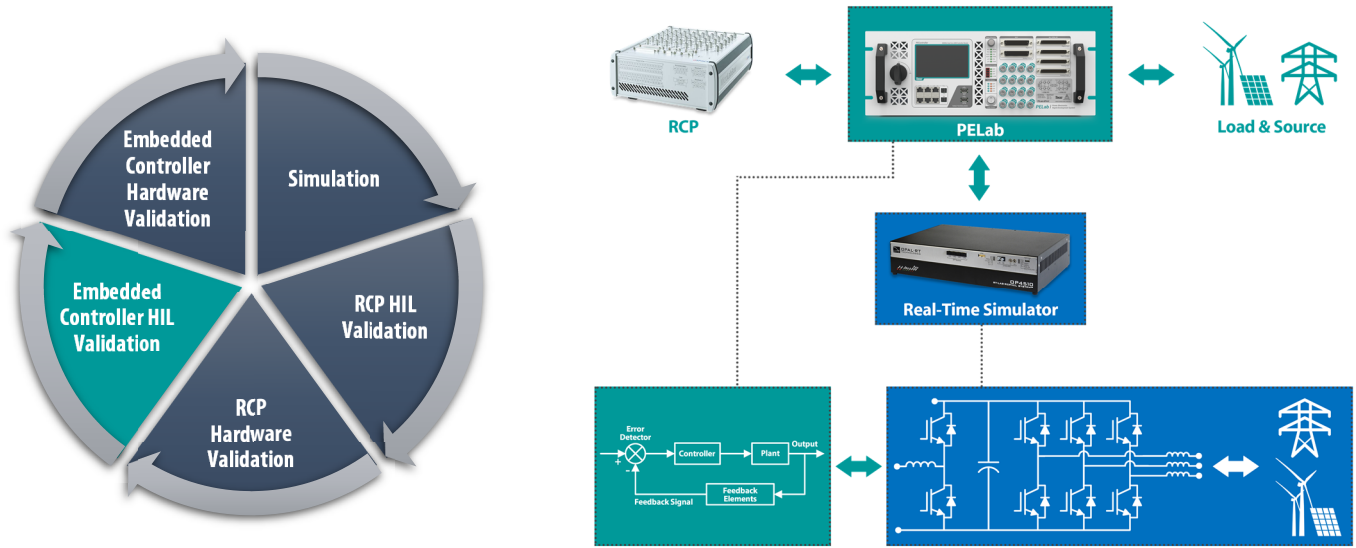

**μC<>HIL Mode Mapping**

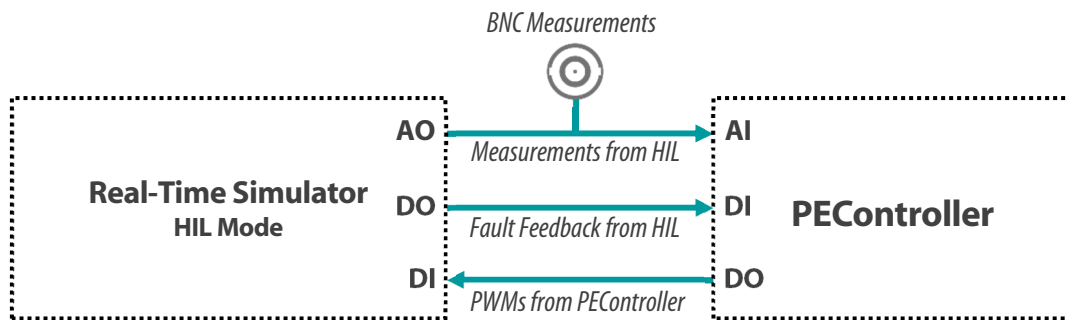

**μC<>PWR MODE: PEController Hardware Validation**

Finally, in microcontroller to power mode, the PEController is tested with the actual inverter inside the PELab. Once done, a standalone inverter is achieved in the PELab.

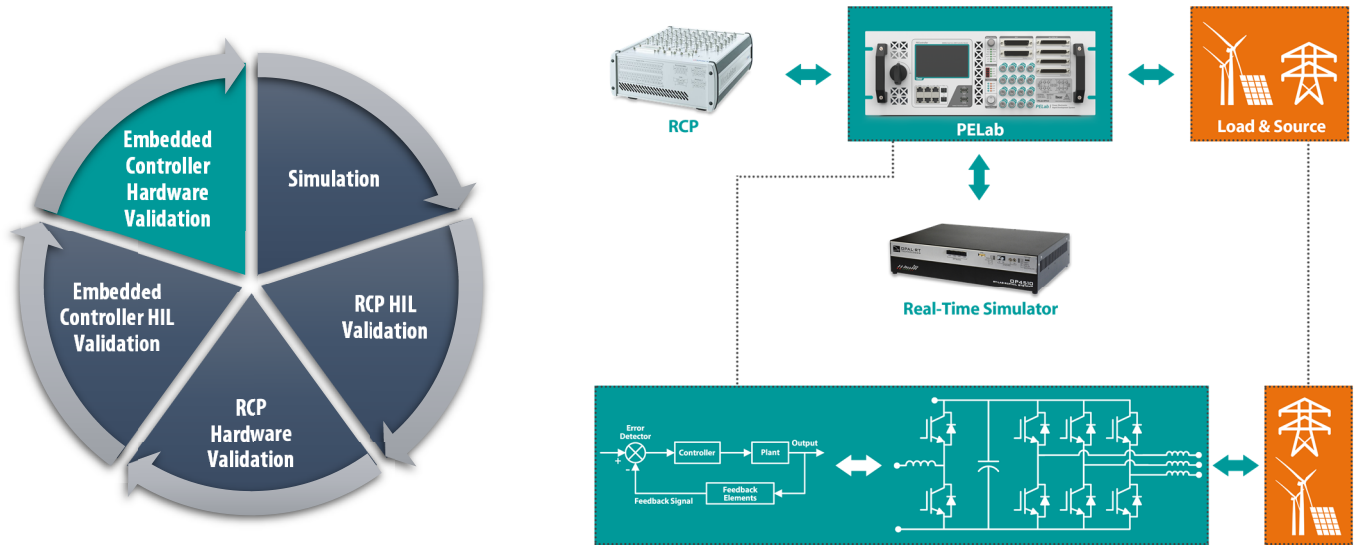

**μC<>PWR Mode Mapping**

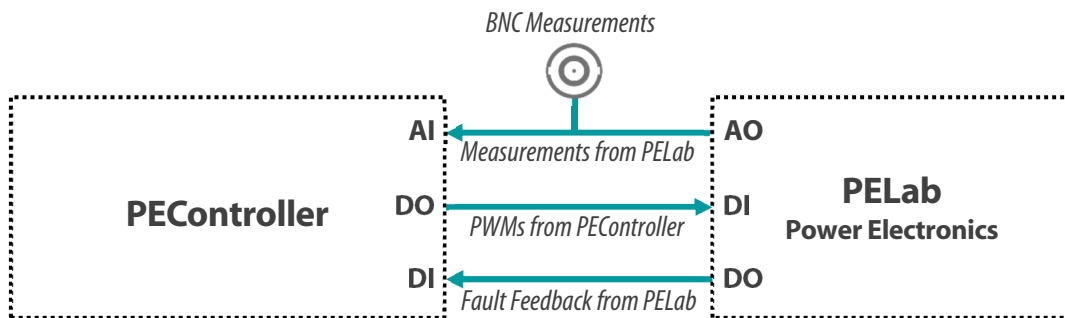

### Pin Mapping & Connections

The PELab interface includes 16 channels of digital and analog inputs and outputs. Following table define all the connections from and to the PELab:

I/O Type	Real-Time Simulator	RCP	PELab PEController	PELab Power Modules
Digital Inputs	<b>16 CH (DI1... DI16)</b> PWMs in HIL Mode Faults in RCP Mode	<b>16 CH (DI1... DI16)</b> Faults Feedback	<b>16 CH (DI1... DI16)</b> Faults Feedback	<b>16 CH (DI1... DI16)</b> PWMs & Relay Control
Digital Outputs	<b>16 CH (DO1... DO16)</b> PWMs in RCP Mode Faults in HIL Mode	<b>16 CH (DO1... DO16)</b> PWMs & Relay Control	<b>16 CH (DO1... DO16)</b> PWMs & Relay Control	<b>16 CH (DO1... DO16)</b> Faults Feedback
Analog Inputs	<b>16 CH (AI1... AI16)</b> HIL Simulated Measurements			<b>Max. 16 CH</b> Sensor Measurements
Analog Outputs	<b>16 CH (CH1... CH16)</b> Sensor Measurements in Power Mode HIL Simulated Measurements in HIL Mode Analog Outputs are Common to BNCs, HIL, RCP and PEController			

### Connectors Pin Mapping

The front panel has the DB37 and DB50 connectors for the real-time simulator and RCP. The pin mapping of those connectors is as following, note that the inputs of PELab to be connected to the outputs of real-time simulator and RCP and vice versa.

#### DB37 Female Connector | HIL/RCP Real-Time Simulator | Digital Inputs

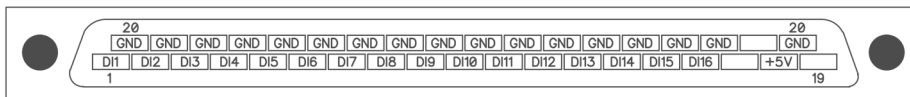

#### DB37 Female Connector | HIL/RCP Real-Time Simulator | Digital Outputs

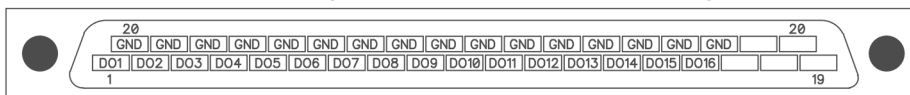

#### DB37 Female Connector | HIL/RCP Real-Time Simulator | Analog Inputs

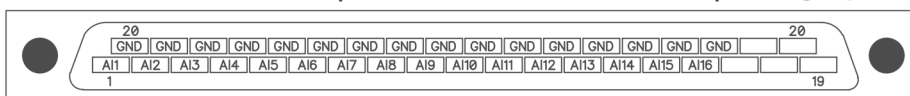

#### DB37 Female Connector | HIL/RCP Real-Time Simulator | Analog Outputs

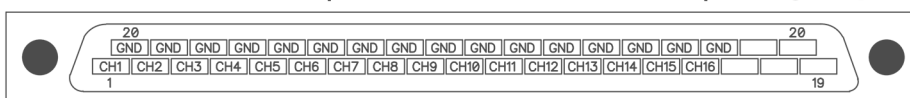

#### DB50 Female Connector | RCP | Digital I/Os

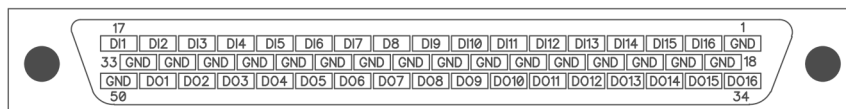

#### DB50 Female Connector | RCP | Analog Outputs

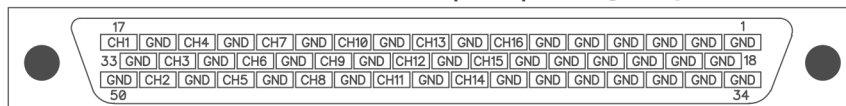

### Analog Channels Mapping

Due to the highly customizable nature of the PELab, a specific measurement mapping label on the front panel is installed for each PELab configuration, the mapping can be easily determined from the label, each CHx corresponds to the respective analog channel in the pin mapping. In addition, sensitivity information of voltage and current channels is also provided.

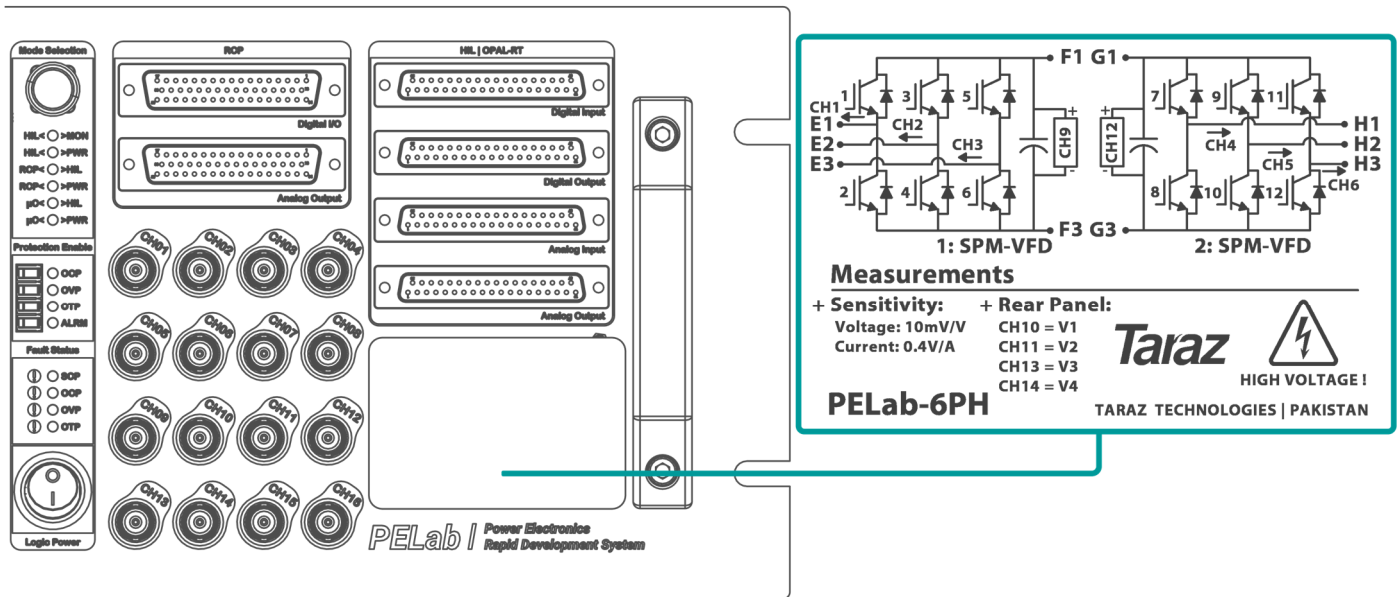

### Digital Channels Mapping

Similarly, the PELab digital inputs and outputs are also customized depending on the PELab configuration as per order. However, the rear panel power module labels will contain the digital input mapping, and in a similar fashion, the switches and relay numbers correspond to the digital input channel number. For example, Q5 PWM input will be DI5 channel of the digital inputs from either the real-time simulator, RCP, or the PEController.

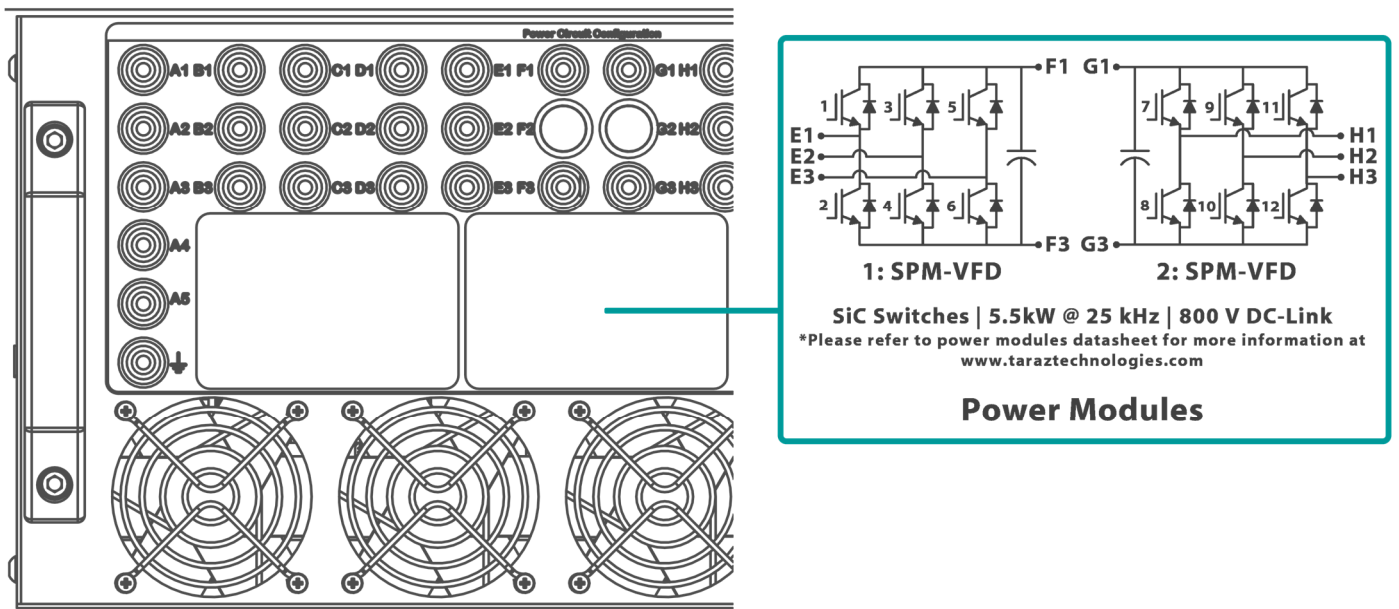

For the digital output channels mapping, please refer to the datasheet that was provided for your ordered configuration of the PELab.

### NOTE!

Each PELab configuration is supplied with a specific datasheet. Always refer to the datasheet first for accurate pin mapping information. An example of a PELab datasheet is provided in Annex A.

## Protections

The PELab includes multiple hardware protections to ensure reliability while developing a new control system, which can result in a destructive condition for power modules in the PELab. These protections are implemented in the interface card.

### Dead-Time Protection

The interface card FPGA which takes the control signals from multiple controllers ensures the minimum dead time between leg switches to safeguard against the shoot-through condition. In addition, it also prevents prohibitive switching states to NPC and TNPC legs. The dead-time logic only inserts minimum dead-time as per the used power modules if the input signal does not have it, otherwise, the signal is forwarded as received from the controller.

### Short Circuit Protection (SCP)

The short circuit protection in the PELab is provided by the gate driver circuit in the power modules using desaturation detection. The gate driver softly shut down the power module to avoid overvoltage on the switch due to the large short circuit current. This fault is latched and therefore, a power reset by the PELab is required to clear the fault. Note that this fault is local, and therefore only the affected power module will be disabled.

### Over Current Protection (OCP)

The overcurrent protection uses hysteresis comparators that can detect an overcurrent condition in less than 5  $\mu$ s. The overcurrent protection trigger level is at least twice the rated leg output current, which allows overload condition for a short period of time until the over-temperature protection kicks in. The OCP can be disabled from the front panel, which may be needed if the load or application requires a shutdown sequence instead of a hard shut down. For example, a motor drive application requires ramp down shutdown to avoid overvoltage conditions due to back EMF from the motor. Note that this fault is local, and therefore only the affected power module will be disabled.

### Over Voltage Protection (OVP)

The overvoltage protection also uses hysteresis comparators that can detect an overvoltage condition in less than 5  $\mu$ s. The overvoltage protection trigger level is only a few volts above the maximum allowed DC-Link voltage. The OVP can be disabled from the front panel as well, which may be needed for certain applications such as Modular Multilevel Converter (MMC). Note that this fault is local, and therefore only the affected power module will be disabled.

### Over Temperature Protection (OTP)

The PELab power modules use a thermostat on the heatsink which is triggered at 85 °C. The trigger will clear once the heatsink is cooled to 55 °C, therefore downtime is required if OTP occurs. The OTP can be disabled from the front panel which may be required by certain applications such as motor drive. Note that this fault is global, and therefore all of the power modules will be disabled.

### **WARNING!**

Disabling the protections can cause permanent damage to the power modules. Use disable functionality only when systematic shutdown at fault condition is required and the controller is fully programmed with it.

### Circuit Configuration

The rear panel labels provide instant visual feedback for circuit configuration. The banana connectors are marked with column letters and row numbers, the schematics on the label contain the mapping information for the power modules, inductors, and filters.

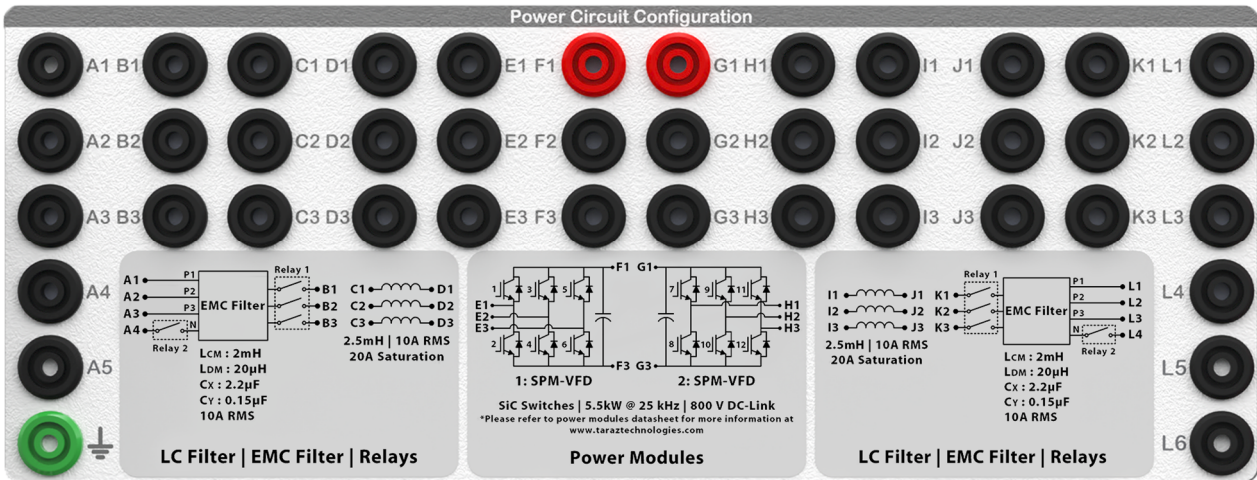

### Application Circuit Wiring Example

To configure a PELab-6PH as a 3 phase solar grid-tie inverter, below connections and measurements will be required. The rear panel voltage sensors will monitor grid voltages and PV input voltage, while the DC-Link voltage and input, output currents are connected internally. The cutoff switch poles are used to isolate the grid from the inverter.

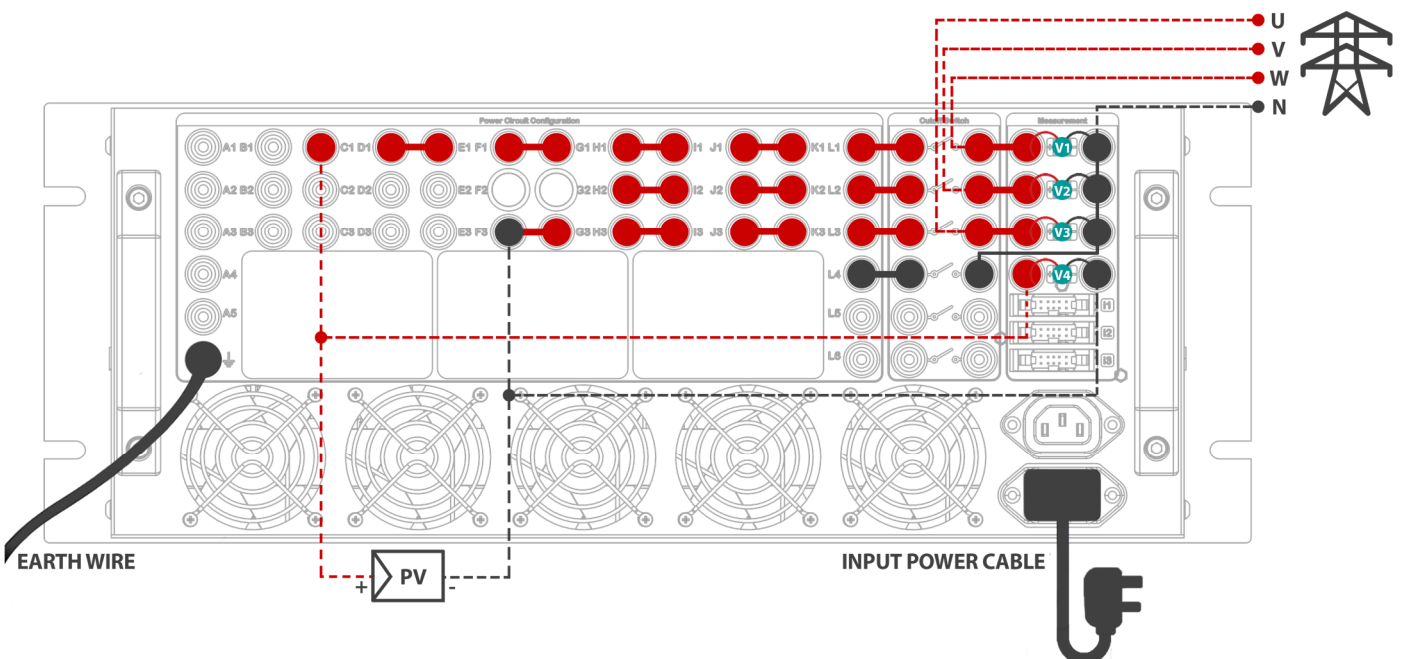
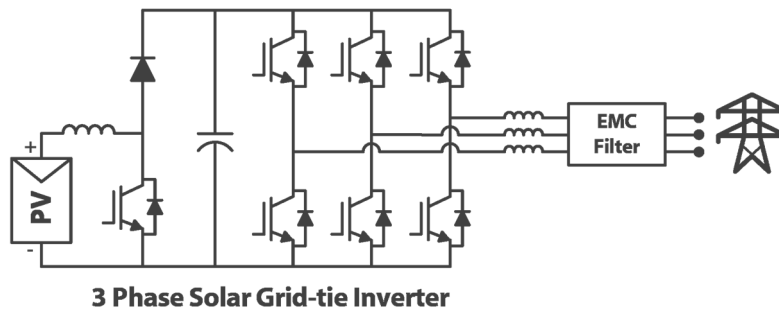

## Operation Procedures & Precautions

Please take following precautions while operating the equipment:

- Do not connect the DC source suddenly to the DC-Link. Due to the large DC-Link capacitor, a high current can flow directly to charge the capacitors which can damage the circuit or blow the internal fuses. To avoid this, connect the power supply first to the DC-Link, then power it up. Since the maximum current is limited at power-up, the overcurrent condition will be avoided.
- Do not connect the AC grid to the inverter output if DC-Link is not connected and powered up by a DC source. A high current can flow through the reverse recovery diodes which can also cause overvoltage conditions in the DC-Link. Therefore, permanent damage can occur.
- In case of an inductive load, always shut down softly and without using the cutoff switch with the load. Due to inductor stored energy, sparking or back EMF can damage the equipment. In this case, turn off the power source to the inverter or softly shut down from the controller.
- Please ensure logic power is always on when the load and source are connected to the PELab, the internal hardware protections are only enabled when the logic power is on.
- Do not disable any of the protections unless software protection is in place in your controller to avoid permanent damage to the PELab.
- Please ensure the earth is always connected for safety.



## PEController Overview

The PEController is an industrial-grade controller module that is specially designed for power electronics applications. It features dual high accuracy 16-bit ADCs that can perform simultaneous sampling at 250 ksps for all the available 16 channels. It also includes the most common industrial communication protocols and a 5" touch display for the user interface. The isolated Sync and Fiber Optic communication enables fast module to module communication and can be used to develop distributed control system or master-slave operation of multiple controllers. The PEController is built using the ST Microelectronics ARM® Cortex® M7 and M4 dual-core STM32H745BI microcontroller. This module can be used for as a reference design for user applications as well as a part of the final product, thus simplifying the application development.

### Connections and Interface

The PELab interfaces with the PEController through the following connectors:

- A** Analog Input: AN1 to AN16
- B** Digital Output A (DO-A): DO1 to DO16
- C** Digital Input (DI): DI01 to DI16

The PEController channels correspond to the same PELab channel numbers, for example, DO5 of the PEController is DI5 of the PELab which goes to DO5 on the DB37 connector in µC to HIL mode.

### Software Requirements

The PEController can be programmed and debugged using the ICP USB port, following are some of the IDE software that can be used:

- STM32CubeIDE (Free & Recommended)
- STM32CubeMX (Free)
- Keil MDK-ARM
- IAR Embedded Workbench for ARM

Our application examples are built using the STM32CubeIDE, and therefore compete project files will be provided in that format.

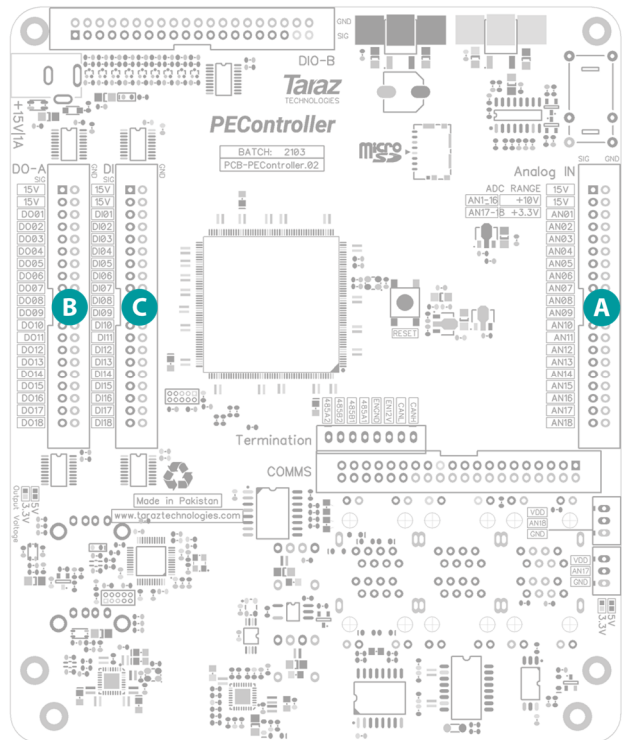
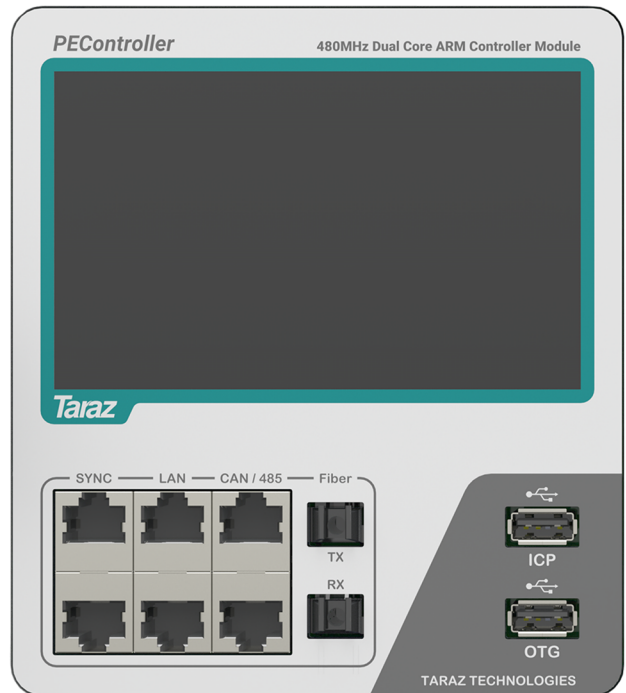

### NOTE!

More information on the PEController can be found in the datasheet.

<https://www.taraztechnologies.com/Downloads/Datasheets/PEController.pdf>

Pin Mapping

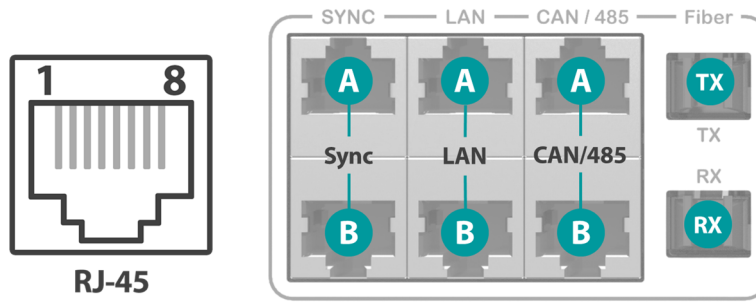

RJ-45	Sync (A&B)		LAN (A)		LAN (B)		CAN / 485 (A&B)	
Pin	Name	Description	Name	Description	Name	Description	Name	Description
1	SYNC-TX+	Sync Transmitter Positive	TX+	Ethernet Transmitter Positive	RX+	Ethernet Receiver Positive	CANH	High-Level CAN Bus Line
2	SYNC-TX-	Sync Transmitter Negative	TX-	Ethernet Transmitter Negative	RX-	Ethernet Receiver Negative	CANL	Low-Level CAN Bus Line
3	GND		RX+	Ethernet Receiver Positive			EN-12V	Enable +
4	GND						EN-GND	Enable -
5	GND						Rs485_A	Transceiver Non-Inverting I/O
6	GND		RX-	Ethernet Receiver Negative			Rs485_B	Transceiver Inverting I/O
7	SYNC-RX-	Sync Receiver Negative						
8	SYNC-RX+	Sync Receiver Positive						
Shield Connected to GND								

**WARNING!**

Use the communication ports only as intended, using wrong wiring or connection can result in permanent damage to the communication port and/or the PEController.

Connection Guide

The PEController communications are intended with certain architectures in mind, which can help in achieving the optimum utilization of the communication port in specific applications. Following are the possible connection architectures:

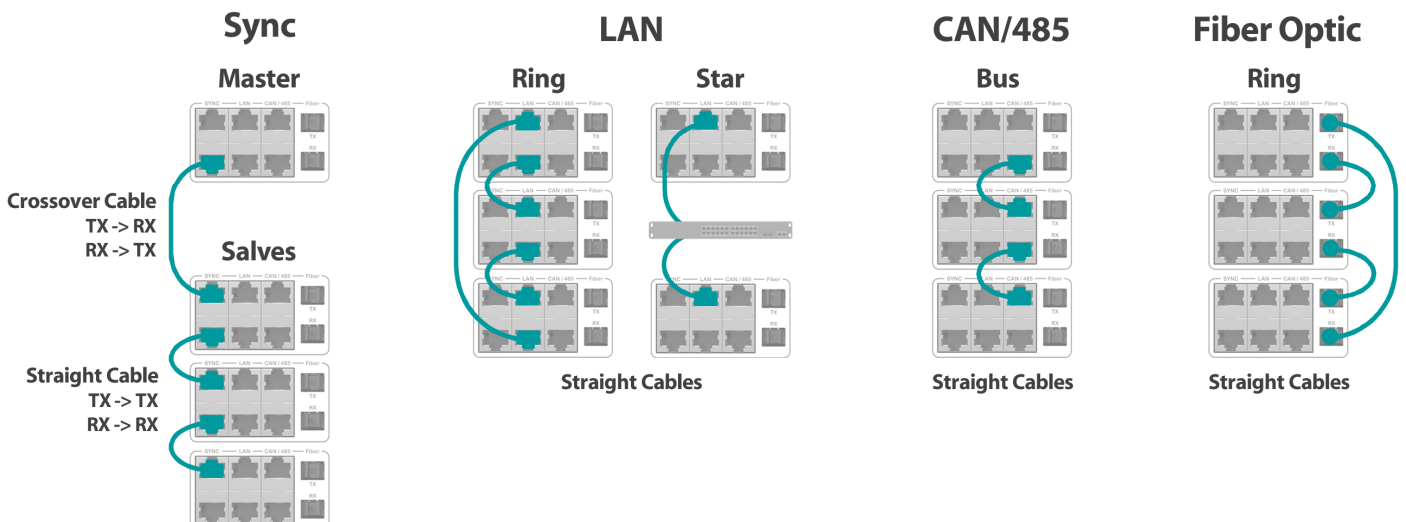

## Resources

For more information and resources on how to use the PEController for your application, following resources are available:

- **Technical Resources & Knowledge Base**

<https://www.taraztechnologies.com/help/>

- **Datasheet**

<https://www.taraztechnologies.com/Downloads/Datasheets/PEController.pdf>

- **Embedded Libraries, Framework & Application Examples**

<https://github.com/Taraz-Technologies/PEControllerBSP>

# ORDERING GUIDE

## Ordering Options

### Power Modules

The PELab is available in four most commonly used power module topologies. Following are the available options:

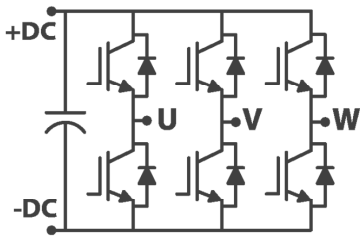

Three Phase Inverter

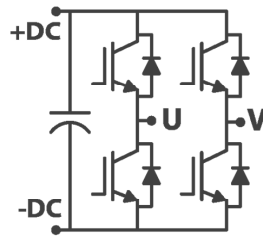

Full Bridge Inverter

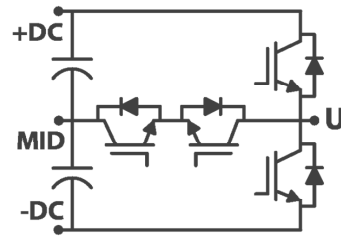

TNPC Leg

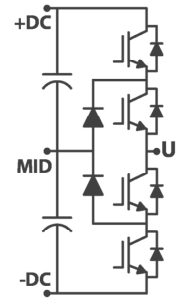

NPC Leg

The power modules can be configured with different power ratings, switching devices and DC-Link capacitors. Following are the available options:

Power Module	Modules Per PELab	Leg Current	DC-Link	Switches Type
PELab-6PH	2	8A	470uF @ 800V	IGBT / SiC
		16A	1500uF @ 400V / 2700uF @ 200V	MOSFET / SiC
		30A	400uF @ 800V	IGBT / SiC
		50A	400uF @ 800V	IGBT / SiC
PELab-MMC / PELab-TNPC	4	8A	470uF @ 800V	IGBT / SiC
		16A	1500uF @ 400V / 2700uF @ 200V	MOSFET / SiC
PELab-NPC	4	8A	117.5uF @ 1000V	IGBT / SiC
		16A	375uF @ 800V / 675uF @ 400V	MOSFET / SiC

**Each PELab can have multiple power modules, and a combination of different modules is also possible.** For example, PELab-TNPC or PELab-NPC can have one Full-Bridge power module similar to the PELab-MMC, and three TNPC or NPC legs respectively. This can be useful for some applications like 3 level solar inverter where the full-bridge power module is used as an interleaved boost and the other 3 legs are used as an inverter.

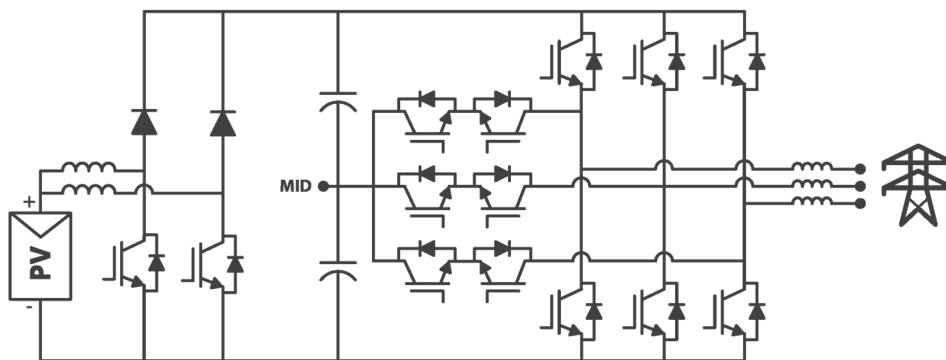

3 Phase 3 Level Solar Grid-tie Inverter

**Inductors, EMC Filters & Relays**

The PELab can also be ordered with inductors, EMC filters, and relays as per requirements, the labels on the rear panel describe the used inductors and EMC filters along with their ratings and specifications.

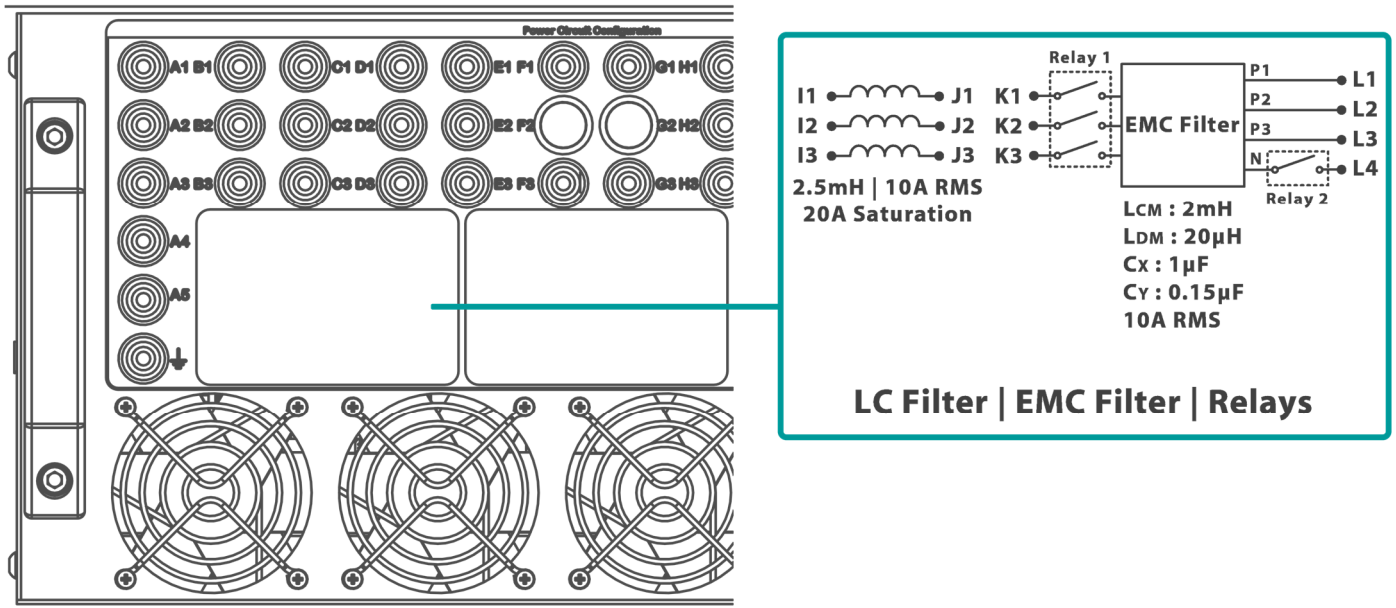

The inductor peak current should not exceed the saturation current specified on the label, normally the OCP trigger level is set to the same value, however, it might be different and therefore the user must ensure the peak current does not exceed the saturation limit.

The specifications of the EMC filter and Relays are also specified on the label, note that relays are not available with the PELab models exceeding 16 switches due to the digital input channel limitation. The specification of the EMC filter corresponds to the following EMC filter circuit:

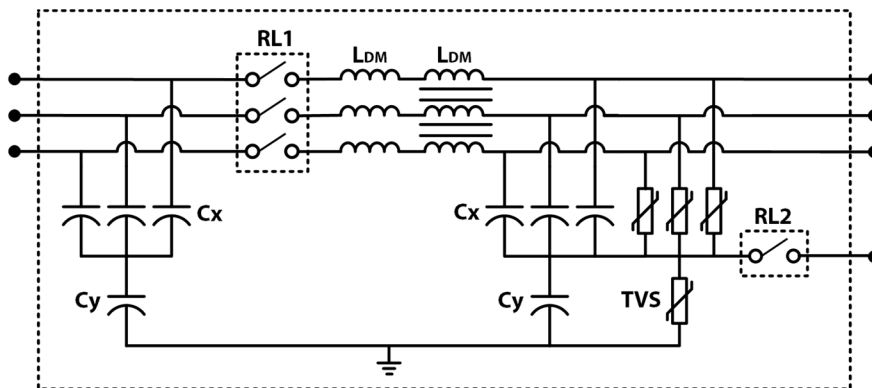

Note: standard TVS Varistor is B72220Q0301K101, which is 300VAC/385VDC capable with 15kA, 235J surge ratings.

**Measurements**

The PELab can be configured with up to 8 channels of voltage and 8 channels of current measurements. The standard sensor used is the USM-3IV which is a fully isolated voltage and current measurement module. It can measure up to ±1000V and ±100A at 100kHz and 200kHz respectively. These measurements will go to the protection circuit as well as the controllers, therefore all the DC-Link voltages and legs output current will be monitored. The remaining voltage and current channels can be assigned to the rear panel optional voltage and current connectors, which are limited to four voltage channels and three current sensors.

**NOTE!**

More information on the measurement module used can be found in the USM-3IV datasheet.

<https://www.taraztechnologies.com/Downloads/Datasheets/USM-3IV.pdf>

## Options Summary & Pricing Information

Please refer to PELab website page for latest information on available options and pricing information.

- <https://www.taraztechnologies.com/pelab/>

## SPECIFICATIONS

### General Specifications

Parameter	Notes	Minimum	Typical	Maximum	Unit
Logic High Input Voltage		2.0	5	5.5	V
Logic Low Input Voltage		-0.3	0	0.8	V
Logic High Output Voltage		4.2	5	-	V
Logic Low Output Voltage		-	-	0.44	V
Propagation Delay	Logic Input to Gate Driver Input	-	20	-	ns
Analog Input Voltage		-10	-	+10	V
Analog Output Voltage		-10	-	+10	V
Over Temperature Protection	Turn On Level	-	85	-	°C
Over Temperature Protection Reset	Turn Off Level	-	55	-	°C
Cutoff Switch Voltage Rating	@ 30 A	-	-	1000	V
Cutoff Switch Current Rating	@ 1000 V	-	-	30	A
Cutoff Switch Current Rating	@ 600 V	-	-	50	A
Banana Connectors Voltage Rating	1000 V CAT III, 600 V CAT IV, reinforced insulation, pollution degree 2	-	-	1000	V
Banana Connectors Current Rating		-	-	30	A
Humidity		-	-	90	%
Ambient Temperature		0	25	40	°C
Cooling Type		Forced Air Cooling			

\*Note: All specifications at 25 °C ambient temperature unless stated otherwise.

### Measurements

Parameter	Voltage Sensor	Current Sensor (1Turn)	Current Sensor (2Turns)	Current Sensor (4Turns)
Range	± 1000 V	± 100 A	± 50 A	± 25 A
Bandwidth	DC – 100 kHz	DC – 200 kHz	DC – 200 kHz	DC – 200 kHz
Rise Time	3.5 μs	1.75 μs	1.75 μs	1.75 μs
Accuracy	1%	1%	1%	1%
Sensitivity	10 mV/V	100 mV/A	200 mV/A	400 mV/A

#### NOTE!

Each PELab configuration is supplied with a specific datasheet. Always refer to the datasheet first for accurate pin mapping information. An example of a PELab datasheet is provided in Annex A.

## Derating Curves

Following are estimated output current derating curves with respect to operating switching frequency based on different switch types. The ambient temperature derating curve is also included. Note that these curves give a general idea of how each technology performs under different switching frequencies and therefore should not be used as a reference. Please refer to the PELab configuration datasheet for more accurate derating curves.

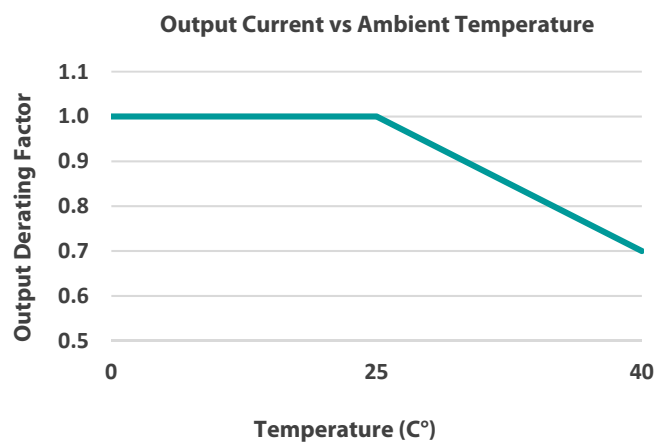
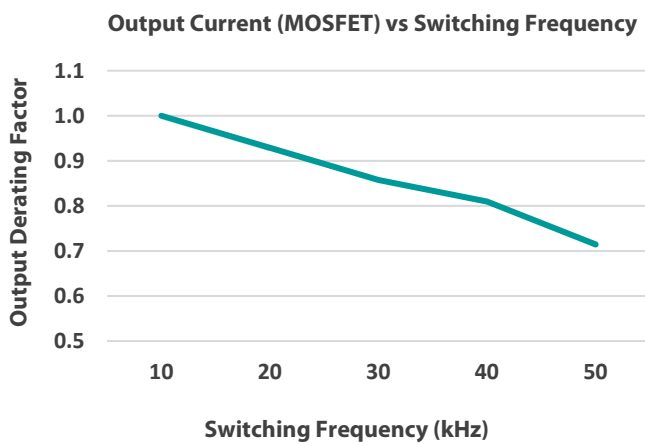
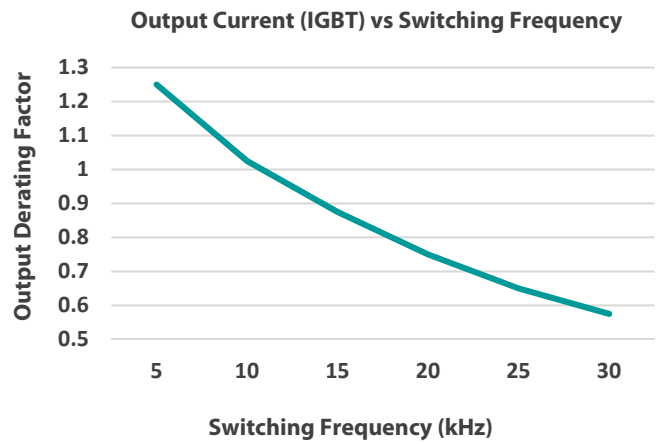
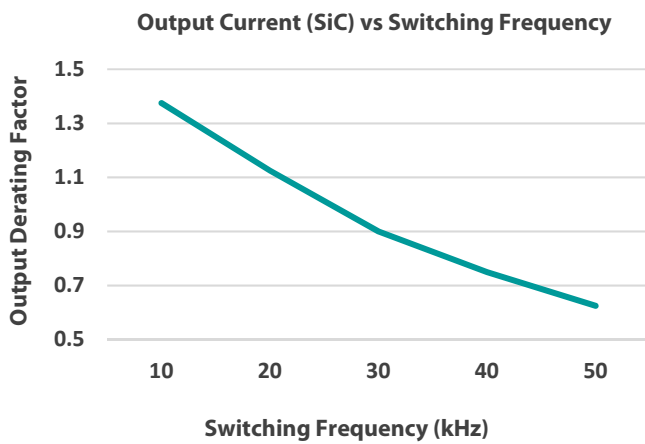

**NOTE!**

Each PELab configuration is supplied with a specific datasheet. Always refer to the datasheet first for accurate derating information. An example of a PELab datasheet is provided in Annex A.



**Mechanical**

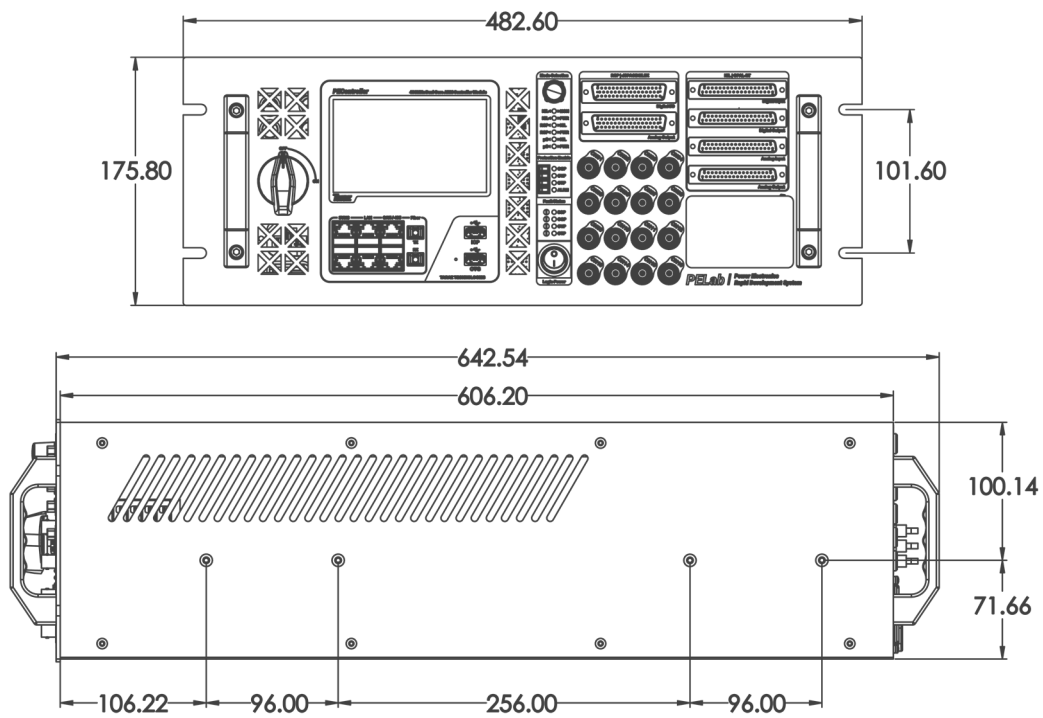

\* Note I: All dimensions in mm.

\* Note II: Drawing is of 19" rack 4U chassis unit, 8U chassis unit will be twice the height.

**NOTE!**

Each PELab configuration is supplied with a specific datasheet. Always refer to the datasheet first for accurate mechanical information. Example of a PELab datasheet is provided in Annex A.

### PELab-6PH Specifications

Parameter/Configuration	8A   470uF @ 800V	16A   1.5mF @ 400V	16A   2.7mF @ 200V	30A   400uF @ 800V	50A   400uF @ 800V
OCP Trigger Level	~ 20 A	~ 40 A	~ 40 A	~ 45 A	~ 90 A
OVP Trigger Level	~ 800 V	~ 400 V	~ 250 V	~ 800 V	~ 800 V
Current Sensor Sensitivity	400 mV/A	200 mV/A	200 mV/A	200 mV/A	100 mV/A
Minimum Dead-Time	0.1 μs (SiC) 0.5 μs (IGBT)	0.15 μs (SiC) 0.3 μs (MOSFET)	0.15 μs (SiC) 0.3 μs (MOSFET)	0.2 μs (SiC) 1 μs (IGBT)	0.2 μs (SiC) 1 μs (IGBT)

### PELab-MMC Specifications

Parameter/Configuration	8A   470uF @ 800V	16A   1500uF @ 400V	16A   2700uF @ 200V
OCP Trigger Level	~ 20 A	~ 40 A	~ 40 A
OVP Trigger Level	~ 800 V	~ 400 V	~ 250 V
Current Sensor Sensitivity	400 mV/A	200 mV/A	200 mV/A
Minimum Dead-Time	0.1 μs (SiC) 0.5 μs (IGBT)	0.15 μs (SiC) 0.3 μs (MOSFET)	0.15 μs (SiC) 0.3 μs (MOSFET)

### PELab-TNPC Specifications

Parameter/Configuration	8A   470uF @ 800V	16A   1500uF @ 400V	16A   2700uF @ 200V
OCP Trigger Level	~ 20 A	~ 40 A	~ 40 A
OVP Trigger Level	~ 800 V	~ 400 V	~ 250 V
Current Sensor Sensitivity	400 mV/A	200 mV/A	200 mV/A
Minimum Dead-Time	0.1 μs (SiC) 0.5 μs (IGBT)	0.15 μs (SiC) 0.3 μs (MOSFET)	0.15 μs (SiC) 0.3 μs (MOSFET)

### PELab-NPC Specifications

Parameter/Configuration	8A   117.5uF @ 1000V	16A   375uF @ 800V	16A   675uF @ 400V
OCP Trigger Level	~ 20 A	~ 40 A	~ 40 A
OVP Trigger Level	~ 950 V	~ 800 V	~ 400 V
Current Sensor Sensitivity	400 mV/A	200 mV/A	200 mV/A
Minimum Dead-Time	0.1 μs (SiC) 0.5 μs (IGBT)	0.15 μs (SiC) 0.3 μs (MOSFET)	0.15 μs (SiC) 0.3 μs (MOSFET)

**NOTE!**

Each PELab configuration is supplied with a specific datasheet. Always refer to the datasheet first for accurate pin mapping information. An example of a PELab datasheet is provided in Annex A.

## ABOUT TARAZ TECHNOLOGIES

Taraz Technologies has been providing research-oriented power electronics solutions to customers in more than 30 countries. Our products include DC/DC Converters, Gate Drivers, Power Modules, Embedded Controllers, Isolated Sensors, Smart Probes, Data Acquisition devices as well as fully integrated Power Electronics Systems. Our product design philosophy focuses on easy-to-use, research-friendly, and modular solutions that can accelerate the research and development cycle while providing maximum versatility for research. Furthermore, our finished product portfolio includes Programmable Power Supplies and Solar Inverters for the domestic market.

Founded in 2012, Taraz was nominated among the top most innovative technology startups in Pakistan. Our research and manufacturing facility is located in Islamabad, the green capital city of Pakistan.

## SAFETY NOTICE

This Device is ESD Sensitive and Needs to be Handled with Care. High Voltage Condition May Occur During Operation of the Device, and Hence User is Solely Responsible for Equipment and Personnel Safety. Taraz Technologies Shall Not be Hold Liable for any Damage to Personnel and/or Properties as a Result of Using this Device. User Must Take Adequate Steps to Ensure Electrical and Mechanical Safety of the Device in Use.

## WARNING & DISCLAIMER

The Information Herein is Given to Describe Certain Components and Shall Not be Considered as a Guarantee of Characteristics. Terms of Delivery and Rights to Technical Change Reserved. We Hereby Disclaim any and All Warranties, Including But Not Limited to Warranties of Non-Infringement, Regarding Circuits, Descriptions, and Charts Stated Herein. Customer is Solely Responsible for Proper and Legal Use of all Products Offered by Taraz Technologies.

Data subject to change. Copyright © 2021 Taraz Technologies. All rights reserved.

## TARAZ WARRANTY

Taraz Technologies warrants its Products against defects in material, workmanship, and design for a period of twelve (12) months. The defective Products will be repaired or replaced, free of charge, as per our standard terms and conditions. For more information on warranty and terms, please visit our website at [www.taraztechnologies.com](http://www.taraztechnologies.com).

## CONTACT

### TARAZ TECHNOLOGIES

21-X, 2nd Floor, DHA Business Avenue, DHA Phase 1,  
Bahria Expressway, Rawalpindi 46000, Pakistan.

**Phone: +92 (51) 5400335**

**Fax: +92 (51) 5400155**

**E-Mail: [sales@taraztechnologies.com](mailto:sales@taraztechnologies.com)**

**Website: [www.taraztechnologies.com](http://www.taraztechnologies.com)**



# ANNEX A

## PELab-6PH Datasheet Sample

This datasheet applies to following PELab Serial No. only:

PLB-6PH-2108-XXXX	PLB-6PH-2108-XXXX		
-------------------	-------------------	--	--

### Power Circuit Configuration & Measurement

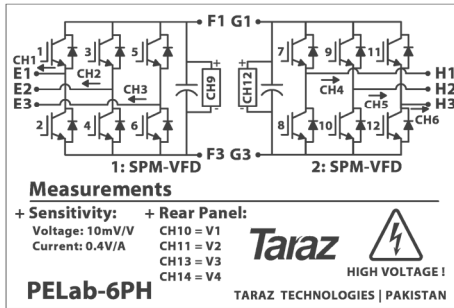
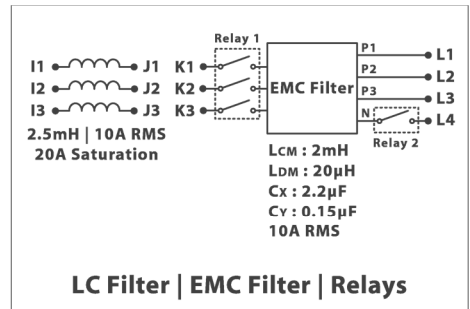
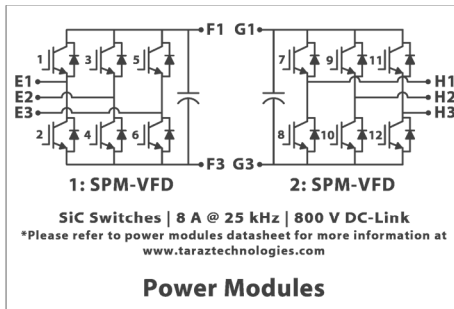
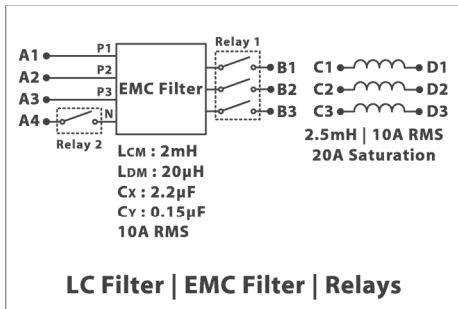

### Specifications

Parameter	Notes	Value
Power Module 1&2 Model		SPM-VFD-SiC
Power Module 1&2 DC-Link	Electrolytic Capacitors	470 µF @ 800 V
Power Module 1&2 Leg Current	Sinusoidal Output RMS Current per Leg	8 A @ 25 kHz
Power Module 1&2 Switch Model	SiC FETs	SCT3080KL
Power Module 1&2 Gate Driver Model		GDC-2A6S1-180-10
Power Module 1&2 Max. Switching Frequency		50 kHz
Power Module 1&2 TVS Varistor Model		V625LA80BP
Power Module 1&2 Fuse		12A   0477012.MXP
PELab Interface Card Revision/Model		PELab.03
PEController Revision/Model		PEController.03
PEController LCD Model		AFY800480B0-5.0N12NTM-C
Inductor Models		Hammond MFG 195E20
OVP Trigger Level		~ 800 V
OCP Trigger Level		~ 20 A
Dimensions	19" Rack, 4U Chassis Unit	483 (W) x 643 (D) x 176 (H) mm
Weight		35.4 kg

### Derating Curves

The following derating curves are available (by calculation) at 25 °C ambient temperature, 600V DC-Link voltage, 25 kHz switching frequency and 8A sinusoidal output RMS current per each leg of the inverter. Derating curves will change if any of the mentioned parameter is varied.

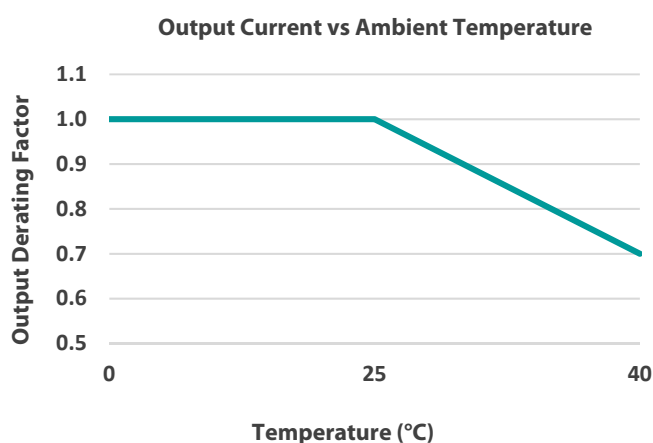
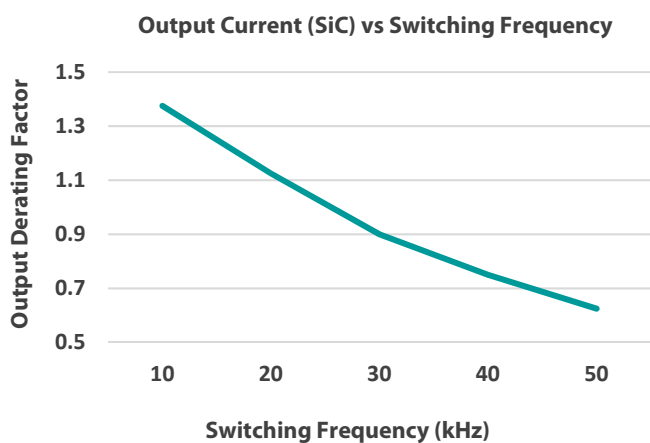

### Pin Mapping

#### Analog I/O Connectors Pin Mapping

Channel	HIL Analog Input (DB37)	HIL Analog Output (DB37)	RCP Analog Output (DB50)	Measurement	Sensitivity
CH1	1	1	17	Current (E1)	0.4V/A
CH2	2	2	49	Current (E2)	0.4V/A
CH3	3	3	32	Current (E3)	0.4V/A
CH4	4	4	15	Current (H1)	0.4V/A
CH5	5	5	47	Current (H2)	0.4V/A
CH6	6	6	30	Current (H3)	0.4V/A
CH7	7	7	13	-	-
CH8	8	8	45	-	-
CH9	9	9	28	Voltage (F1-F3)	10mV/V
CH10	10	10	11	V1 (Back panel)	10mV/V
CH11	11	11	43	V2 (Back Panel)	10mV/V
CH12	12	12	26	Voltage (G1-G3)	10mV/V
Ch13	13	13	9	V3 (Back Panel)	10mV/V
CH14	14	14	41	V4 (Back Panel)	10mV/V
CH15	15	15	24	-	-
Ch16	16	16	7	-	-

**Digital Input Connectors Pin Mapping**

Channel	HIL Digital Input (DB37)	RCP Digital I/O (DB50)	Inverter Signal
DI1	1	17	High Side Switch (E1)
DI2	2	16	Low Side Switch (E1)
DI3	3	15	High Side Switch (E2)
DI4	4	14	Low Side Switch (E2)
DI5	5	13	High Side Switch (E3)
DI6	6	12	Low Side Switch (E3)
DI7	7	11	High Side Switch (H1)
DI8	8	10	Low Side Switch (H1)
DI9	9	9	High Side Switch (H2)
DI10	10	8	Low Side Switch (H2)
DI11	11	7	High Side Switch (H3)
DI12	12	6	Low Side Switch (H3)
DI13	13	5	Disable (Power Module 1)
DI14	14	4	Disable (Power Module 2)
DI15	15	3	RL1 (Relay 1 Control)
DI16	16	2	RL2 (Relay 2 Control)

**Digital Output Connectors Pin Mapping**

Channel	HIL Digital Output (DB37)	RCP Digital I/O (DB50)	Inverter Signal
DO1	1	49	SCP (Power Module 1 Fault)
DO2	2	48	SCP (Power Module 2 Fault)
DO3	3	47	-
DO4	4	46	-
DO5	5	45	OCP (E1 Leg)
DO6	6	44	OCP (E2 Leg)
DO7	7	43	OCP (E3 Leg)
DO8	8	42	OCP (H1 Leg)
DO9	9	41	OCP (H2 Leg)
DO10	10	40	OCP (H3 Leg)
DO11	11	39	OVP (Power Module 1)
DO12	12	38	OVP (Power Module 2)
DO13	13	37	-
DO14	14	36	-
DO15	15	35	OTP (Power Module 1&2)
DO16	16	34	-

**NOTE!**

Please refer to PELab User Guide for more information on pin mapping and multiplexing logic of each operation mode.

## ABOUT TARAZ TECHNOLOGIES

Taraz Technologies has been providing research-oriented power electronics solutions to customers in more than 30 countries. Our products include DC/DC Converters, Gate Drivers, Power Modules, Embedded Controllers, Isolated Sensors, Smart Probes, Data Acquisition devices as well as fully integrated Power Electronics Systems. Our product design philosophy focuses on easy-to-use, research-friendly, and modular solutions that can accelerate the research and development cycle while providing maximum versatility for research. Furthermore, our finished product portfolio includes Programmable Power Supplies and Solar Inverters for the domestic market.

Founded in 2012, Taraz was nominated among the top most innovative technology startups in Pakistan. Our research and manufacturing facility is located in Islamabad, the green capital city of Pakistan.

## SAFETY NOTICE

This Device is ESD Sensitive and Needs to be Handled with Care. High Voltage Condition May Occur During Operation of the Device, and Hence User is Solely Responsible for Equipment and Personnel Safety. Taraz Technologies Shall Not be Hold Liable for any Damage to Personnel and/or Properties as a Result of Using this Device. User Must Take Adequate Steps to Ensure Electrical and Mechanical Safety of the Device in Use.

## WARNING & DISCLAIMER

The Information Herein is Given to Describe Certain Components and Shall Not be Considered as a Guarantee of Characteristics. Terms of Delivery and Rights to Technical Change Reserved. We Hereby Disclaim any and All Warranties, Including But Not Limited to Warranties of Non-Infringement, Regarding Circuits, Descriptions, and Charts Stated Herein. Customer is Solely Responsible for Proper and Legal Use of all Products Offered by Taraz Technologies.

Data subject to change. Copyright © 2021 Taraz Technologies. All rights reserved.

## TARAZ WARRANTY

Taraz Technologies warrants its Products against defects in material, workmanship, and design for a period of twelve (12) months. The defective Products will be repaired or replaced, free of charge, as per our standard terms and conditions. For more information on warranty and terms, please visit our website at [www.taraztechnologies.com](http://www.taraztechnologies.com).

## CONTACT

### TARAZ TECHNOLOGIES

21-X, 2nd Floor, DHA Business Avenue, DHA Phase 1,  
Bahria Expressway, Rawalpindi 46000, Pakistan.

**Phone:** +92 (51) 5400335

**Fax:** +92 (51) 5400155

**E-Mail:** [sales@taraztechnologies.com](mailto:sales@taraztechnologies.com)

**Website:** [www.taraztechnologies.com](http://www.taraztechnologies.com)

